



USER MANUAL

MODEL:

SLX-MS3-PF-RN-PF

PUMP FED FOAM, RINSE, FOAM - MULTI STATION

English (Original Instructions)

Updated: 04/27/22

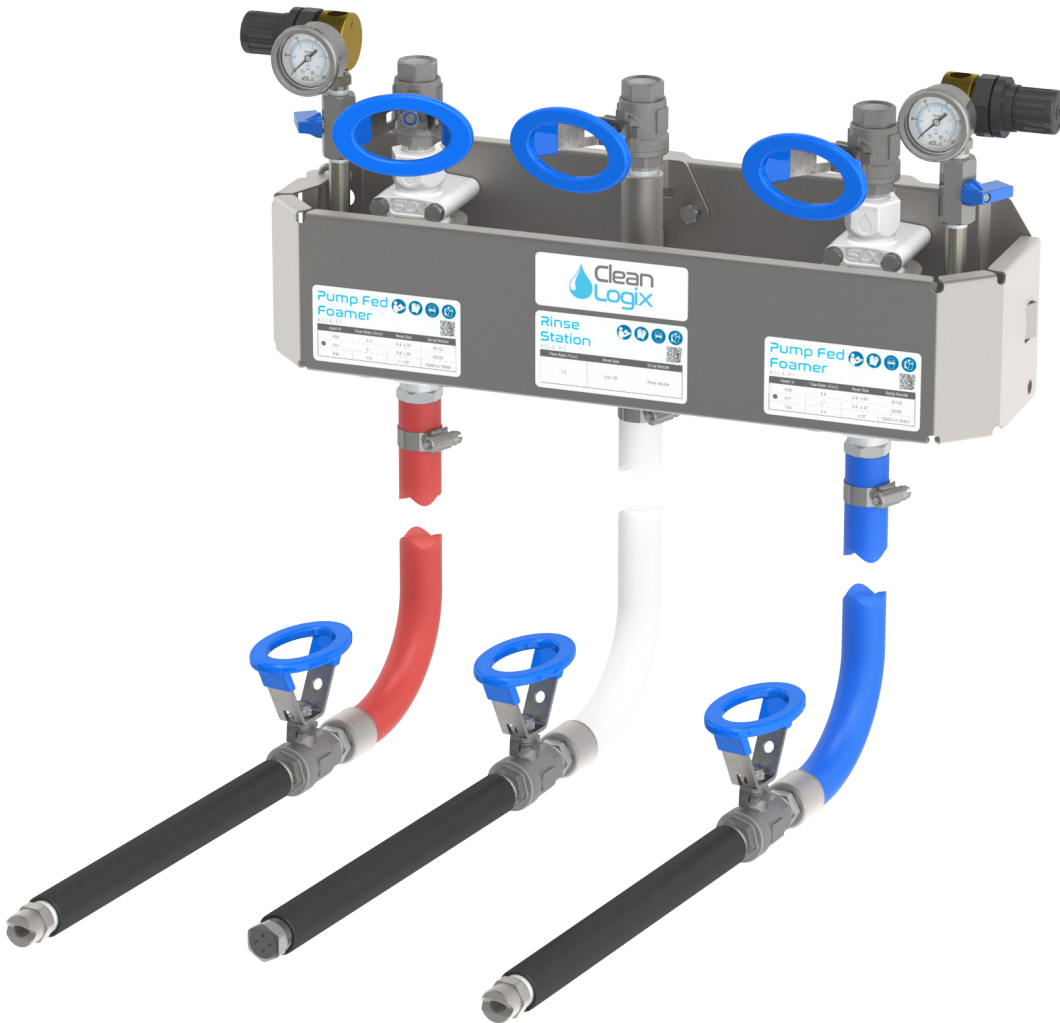



Table of Contents

System Requirements	03
Installation	04
Operation	05
General Use	07
Maintenance	09
Troubleshooting	10
Parts Call Out	12

General Precautions

- For proper performance **do not** substitute nozzle or alter the diameter or length of the included hose.
- **Never** point the spray wand at another individual or electrical devices. Always direct the discharge away.
- For pressures over 100 PSI, remove the discharge valve or lower pressure.
- **Never** leave water or air supply inlet ball valves on when unit is not in use.
- **Never** mix chemicals without consulting the chemical manufacturer first.
- Manufacturer assumes no liability for the use or misuse of this unit or chemical compatibility.
- Specifications and parts are subject to change without notice.



Safety Warning



- All personnel servicing this unit must be familiar with the information contained in this manual. Follow all installation and maintenance instructions.
- Follow safety instructions of chemical manufacturer (SDS).
- Wear proper PPE when working with chemicals (gloves, safety glasses, face shield, etc.)
- Always follow plant and OSHA guidelines.

- Avoid contact of chemicals with skin and eyes. If contact occurs, see SDS sheet for further first aid measures.
- Follow all local codes for backflow prevention when connecting to a potable pump supply.
- **WARNING: Severe damage to your facility, or contamination of your pump supply, can occur without proper backflow prevention.**

PROTECT THE ENVIRONMENT

Please dispose of packaging materials, old machine components, and hazardous fluids in an environmentally safe way according to local waste disposal regulations.



Always remember to recycle.



Overview

The SLX Double Foam & Rinse multi-station provides an all-in-one cleaning system for industrial processing equipment using ready to use (RTU) cleaning solutions (35-125 PSI) from one location with separate discharge hoses.

This low to medium volume centralized cleaning and sanitation system uses a pump to supply cleaning solutions to two, individual, foam proportioners. All three systems (rinse station and both foamers) are securely mounted onto a stainless-steel wall bracket for easy installation.

Requirements

- Pressure: 35 - 125 PSI

NOTE: A back flow preventer must be installed in the pump supply to this unit, per local codes.

- Max Temperature: 160°F
- Air Pressure: 40 PSI recommended
- Chemical compatibility: Chemical products used with this equipment must be formulated for this type of application and compatible with unit materials (see specifications).

NOTE: For more information on chemical compatibility consult the chemical manufacturer.

Specifications

- Materials of Construction:
 - Body: Polypropylene
 - Enclosure: 304SS
 - Wetted Parts: PVC, Polypropylene, AFLAS, and Stainless Steel
- Weight:
 - Foamer with enclosure: 17 lbs.
 - Hose Assembly: 13 - 17.5 lbs.
 - Spray wand: 1.3 - 1.75 lbs.
- Dimensions: 20-1/4" x 17-3/8" x 6"

NOTE: Weights will vary depending on model configuration and construction materials.

Insert #	Coverage Time (sq/ft per min.)	Foam Flow Rate (GPM)	Water Flow Rate (GPM)	Hose Size (OD x L)	Spray Nozzle
P21	250	10.5 - 21	2.1	3/4" x 50'	50250

Flow rates and coverage time may vary depending on supply pressure, metering tip size, and chemical viscosity. Always test prior to normal operation to ensure facility requirements are met for cleaning procedures.



More Information

Please contact Clean Logix at:

(616)-438-9200 or **sales@clean-logix.com**

USER MANUAL: SLX-MS3-PF-RN-PF

READ ALL INSTRUCTIONS BEFORE OPERATING EQUIPMENT



Installation

1. Mount the enclosure to the wall.
2. Flush air and pump supply lines to ensure they are flowing properly and free of debris.
3. Connect air to air inlets (1/4" NPT)

NOTE: Air filter recommended

4. Connect pump supply to foamer inlets (1/2" NPT)
5. Connect water supply to rinse station (1/2" NPT)
6. Connect discharge hoses and spray wands to the bottom hose barb and secure with hose clamps.

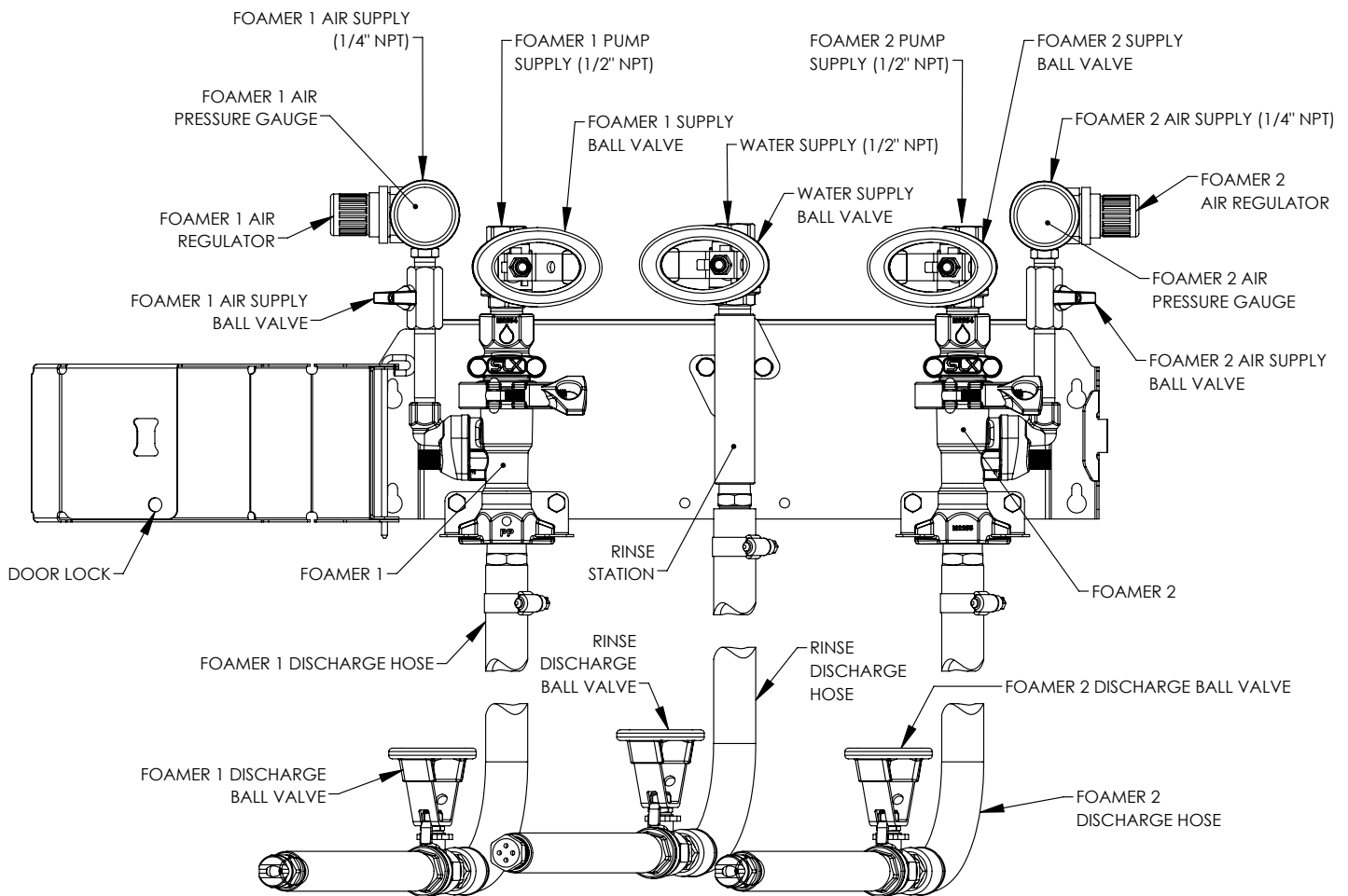
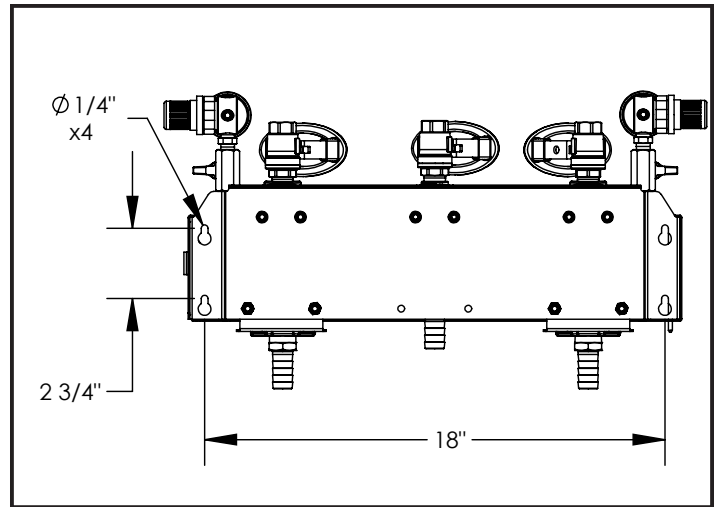



Operation

Initial Use

When operating the foamers for the first time some alterations may need to be made to produce the desired foam quality for each system.

1. Ensure foamer is properly connected and the pump and air supply valves are closed [Fig. 5.1]
2. Take hold of the spray wand.
3. Open ball valve on spray wand [Fig. 5.2]
4. Fully open pump supply valve.
 - The spray wand will slowly begin discharging liquid solution.
5. Fully open air valve.
 - There will be a kick of pressure as the spray wand recoils from the air pressure.
6. Foam will begin to initiate.
 - This may appear uneven at first but as the air and water pressure stabilize the quality of the foam will become more uniform.
7. To alter foam consistency adjust the air pressure:
 - **Dryer Foam** - Increase air pressure (turn dial clockwise).
 - **Wetter Foam** - Decrease air pressure (turn dial counter-clockwise).

NOTE: Always keep air pressure BELOW pump pressure!

8. Check foam quality per facility standards.

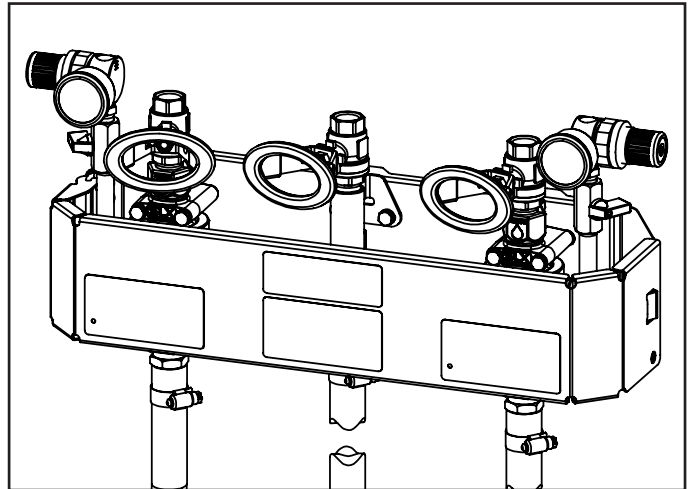

Fig. 5.1: Water and air supply ball valves closed.

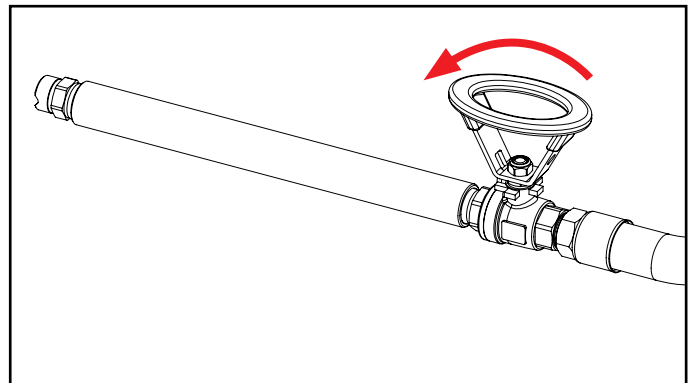

Fig. 5.2: Spray wand with open valve.

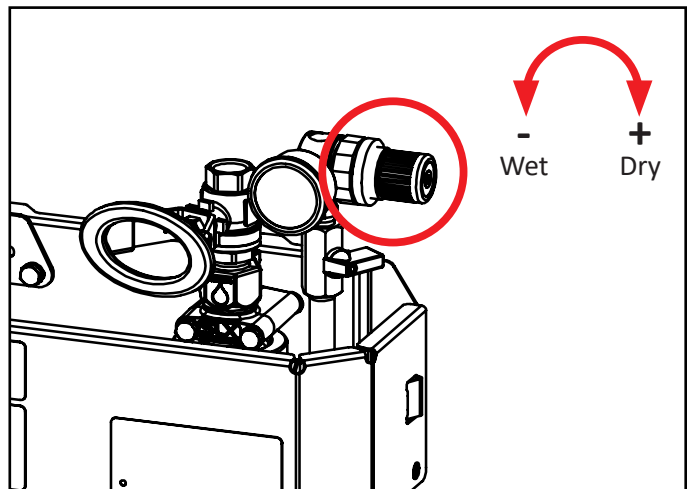

Fig. 5.3: Air pressure adjustment for foam quality.



Operation (cont.)

Normal Use

1. Ensure the unit is properly connected and the pump and air supply valves are closed.
2. Take hold of the spray wand.
3. Open ball valve on spray wand.
4. Fully open supply valve.
 - The spray wand will slowly begin discharging water.
5. **[Foamers]** Fully open air valve.
 - There will be a kick of pressure as the spray wand recoils from the air pressure
 - Foam will begin to initiate - This may appear uneven at first but as the air and supply pressure stabilize the quality of the foam will become more uniform.
6. Apply foam from bottom to top, ensuring even coating.
7. Turn spray wand ball valve off to temporarily stop foaming.

WARNING

Spray wand ball valve should only be turned off momentarily when under pressure. There will be kick-back/recoil when re-opening.

8. Rinse, from top to bottom, before foam dries.
9. When complete, turn off supply lines.
10. Open spray wand ball valve and let foam pressure exhaust completely.
11. Rinse hose(s) as necessary.
12. Store hose depressurized, with the ball valve open and coiled properly coiled to prevent kinks or damage.

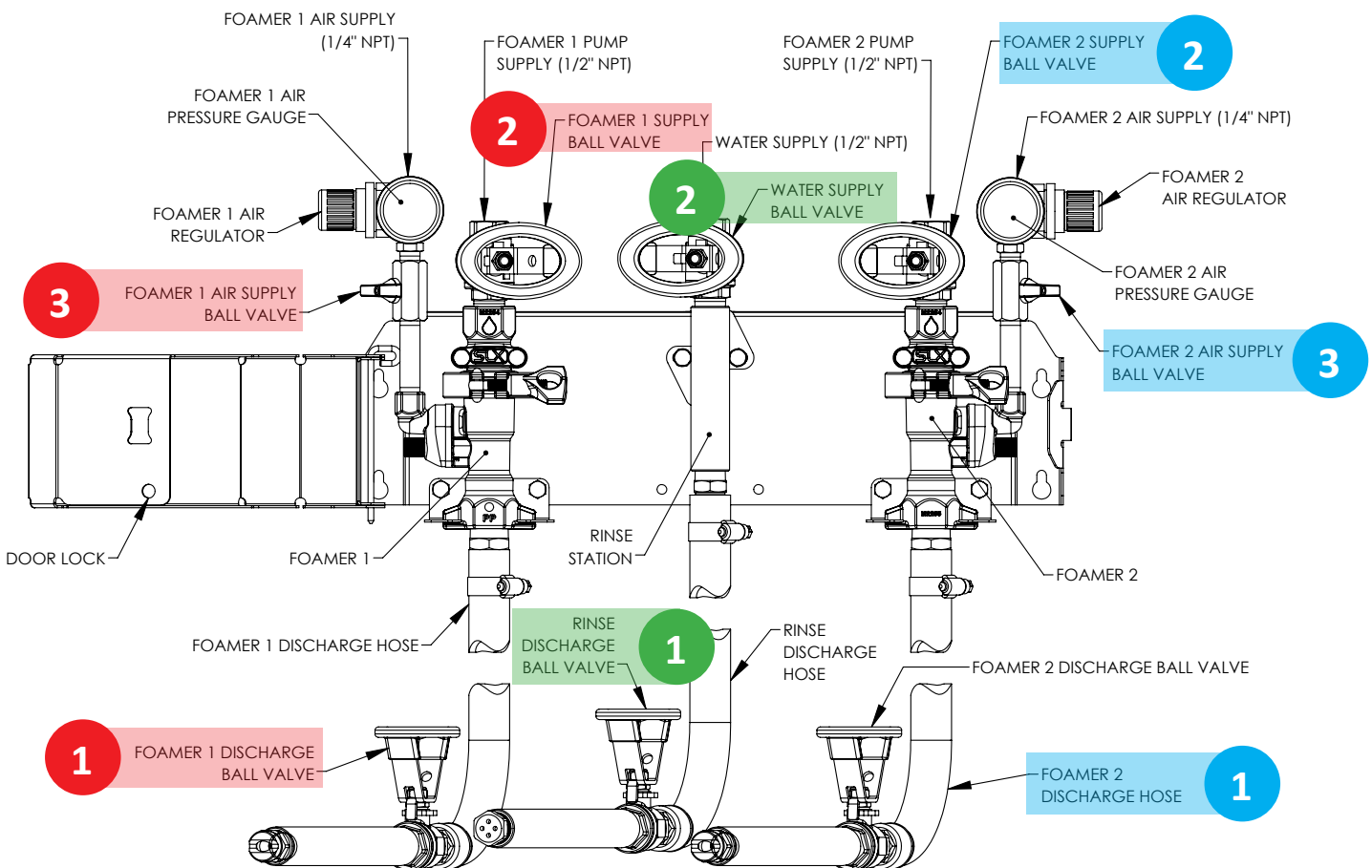

General Use

Removing Insert

1. Ensure supply lines are off and system is depressurized.

WARNING

Depressurize system prior to servicing! Always wear appropriate personal protective equipment (PPE) when handling chemical per SDS recommendations.

2. Open the enclosure door.
3. Loosen the tri-clamp fitting to disconnect the upper body and lower body.

NOTE: Supply lines and discharge hose can remain connected during this process. Ensure there is adequate hose/tubing length for maneuverability.

4. Pull the lower body down, away from the upper section.

WARNING

An o-ring is positioned between the upper and lower bodies. Ensure it is not lost during servicing.

5. With the bottom half removed the Pump Fed insert can be accessed; pull straight down to remove.
 - Force may be required due to o-rings and/or chemical build-up.
 - A screwdriver can be used to pry the insert out if necessary [Fig. 7.2]
6. The insert can be cleaned using warm water or descaling acid compatible with PVC.

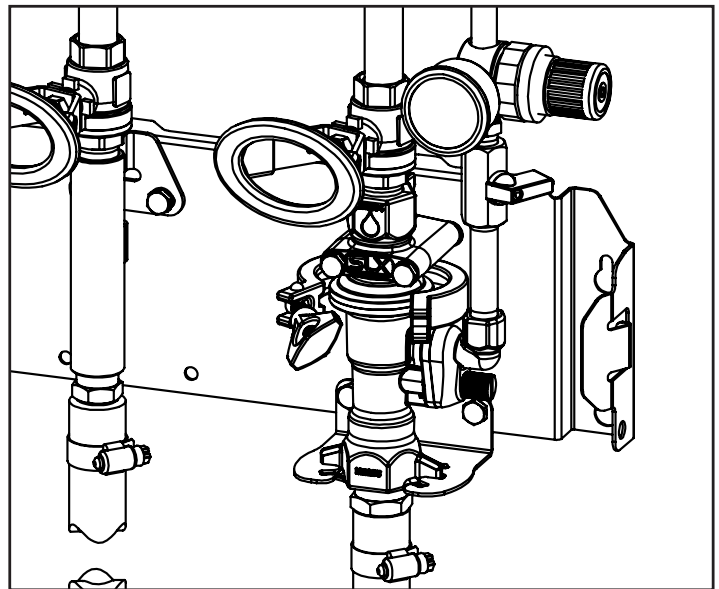

Fig. 7.1: Tri-clamp open on Foamer

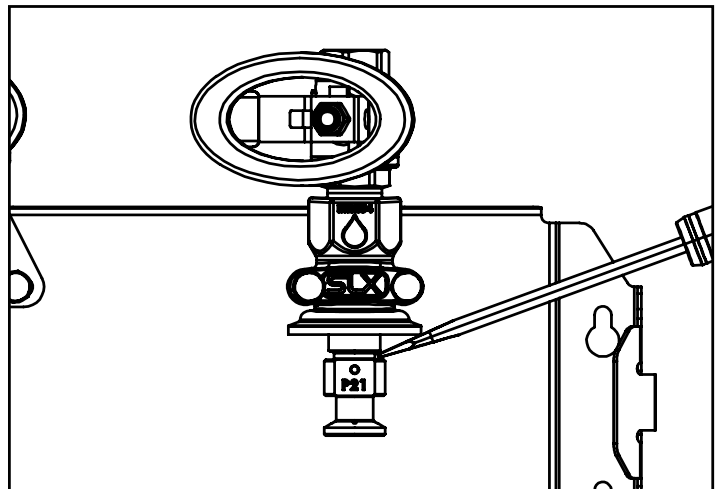

Fig. 7.2: Pump Fed insert removal using screwdriver

General Use (cont.)

Removing Pump Fed Insert (cont.)

7. Replace insert with clean or new version by sliding it back into the upper Pump Fed body, o-ring section first.
8. Reconnect the lower body to the upper section.

WARNING

Ensure o-ring is positioned between the upper and lower bodies and is seated properly. Failure to do so may result in leaks or improper performance.

9. Place the tri-clamp around the lip where the two halves meet, tighten in place until secure.
10. Ensure gauge is facing forward and all connection points are secure.
11. Close enclosure door and lock if necessary.
12. Follow initial setup procedures to test insert and foam quality before resuming normal operation.

Removing Check Valve

1. Ensure supply lines are off and system is depressurized.
2. Open the enclosure door
3. Loosen the thumb screw on the elbow by hand or using a flathead screwdriver. [Fig 8.2]
4. Pull the elbow away from the foamer body.
5. The check valve will be seated either inside of the elbow or the foamer body. Grab it and pull to remove. [Fig 8.3]
6. Clean or replace if damaged.
7. To reinsert, orient the check valve with the arrow pointing towards the foamer body and press into place.
8. Reattach the elbow and tighten the thumb screw until secure.

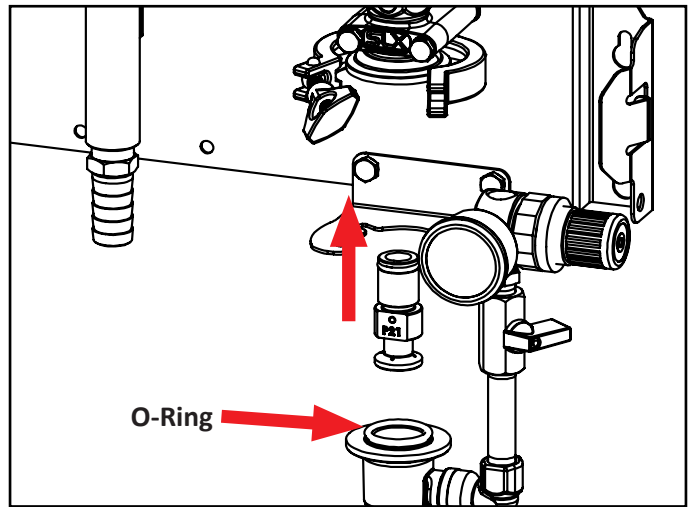

Fig. 8.1: Replacing Pump Fed insert and foamer body

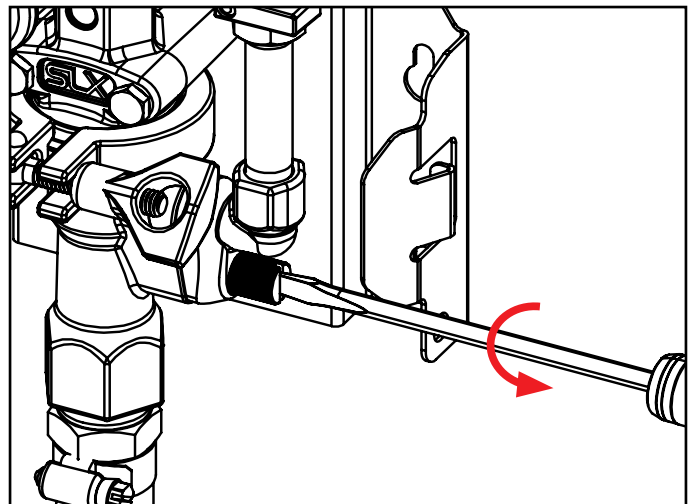

Fig. 8.2: Loosening thumb screw on elbow (air inlet)

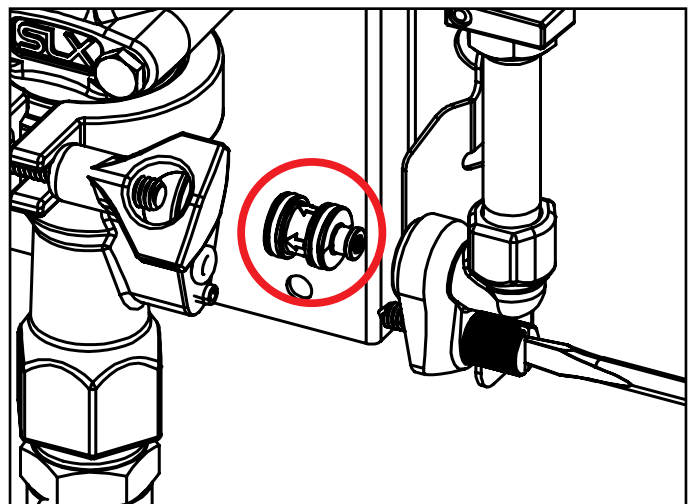

Fig. 8.3: SLX Check Valve (correct orientation)



Maintenance

The following maintenance procedures are recommended for normal use. Units which see a high amount of use should be inspected more frequently.

WARNING

Depressurize system prior to servicing! Always wear appropriate personal protective equipment (PPE) when handling chemical per SDS recommendations.

Daily:

- Check condition of hose (damage or leaks)
 - Replace as necessary.
- Ensure air or pump supply lines are not receiving backflow of chemistry or air.
 - Ensure check valve is operating properly, replace as necessary.
- Verify ball valves are operating properly.
 - Replace as necessary.

Weekly:

- Ensure tri-clamp is secure and bodies are sealed
 - Verify o-ring is seated properly and is not damaged. Replace as necessary.
 - Check that tri-clamp is seated properly and tighten till secure.

Monthly

- Verify check valve is operating properly
 - Remove and ensure spring is functioning properly. Replace as necessary.
- Check insert for clogs and debris.
 - Remove and inspect - if clogged or scale has built up clean with water or de-scaling acid compatible with PVC.
- Check o-rings on inserts and check valves.
 - Remove and replace as necessary.
 - O-rings can be purchased individually or pre-installed as complete check valve or insert assemblies.

Annually

- Replace discharge hose (and wand if necessary)
- Replace insert, check valve, regulator, and gauge



More Information

Please contact Clean Logix at:

(616)-438-9200 or sales@clean-logix.com



Troubleshooting

Foam surges, bucks, and/or recoils

	Cause	Solution
Start-up	Air pressure too high	Lower the air pressure using the included regulator slowly until output stabilizes.
	Pump pressure or volume too low/inlet piping too small.	Increase pump pressure or volume
	Inlet or discharge ball valve is not completely open	Completely open the ball valves.
	Improper chemical	Ensure product is recommended for foaming and the intended application.
	Discharge hose too long or wrong size or kinked	Straighten the hose or replace hose with correct size and length.
	Nozzle size too small	Replace nozzle with correct size.
	Oil or lubricant is present in airline	Use only clean, dry air.
Extended Use	Foamer insert is clogged	Open foamer body and check for debris or obstructions. Clean as necessary with water or air.
	Improper air pressure	Check regulator settings. Clean or replace as necessary.
	Air inlet check valve stuck or failed	Clean or replace.
	Hard water scale or chemical build-up may have formed in the foamer body.	Open foamer body and check for build-up. Remove and clean with water or descaling acid (insert is PVC). Replace as necessary.

Foamer does not clean properly or Foam is too dry

Cause	Solution
Air pressure too high	Lower the air pressure using the included regulator slowly until output stabilizes.
Improper chemical	Ensure product is recommended for foaming and the application.
Hose may be damaged or kinked.	Straighten the hose, replace if damaged.
Incorrect discharge hose, wand, and/or nozzle size.	Verify size and replace if necessary with correct size and length (see system specifications based on insert size)

For Technical Support:





Troubleshooting

Foam is too wet

	Cause	Solution
Start-up	Inlet or discharge ball valve is not completely open	Completely open the ball valves.
	Improper chemical	Ensure product is recommended for foaming and the application.
	Discharge hose too long or wrong size or kinked	Straighten the hose or replace hose with correct size and length.
	Nozzle size too small	Replace nozzle with correct size.
	Oil or lubricant is present in airline	Use only clean, dry air.
Extended Use	Improper air pressure	Check regulator settings. Clean or replace as necessary.
	Air check valve stuck or failed	Clean or replace.
	Hard water scale or chemical build-up may have formed in the foamer body.	Open foamer body and check for build-up. Remove and clean with water or descaling acid (insert is PVC). Replace as necessary.

Solution is backing up into air supply line

Cause	Solution
Air check valve failed	Clean and replace as necessary
Discharge ball valve left closed with inlet ball valves open	Close incoming supply lines and depressurize system when complete. Discharge ball valve should only be used for temporary shut-off during cleaning applications.

Air is backing up into pump supply line

Cause	Solution
Inlet ball valve left on when not in use	Turn off ball valve

For Technical Support:



USER MANUAL: SLX-MS3-PF-RN-PF

READ ALL INSTRUCTIONS BEFORE OPERATING EQUIPMENT



Parts Call-Out

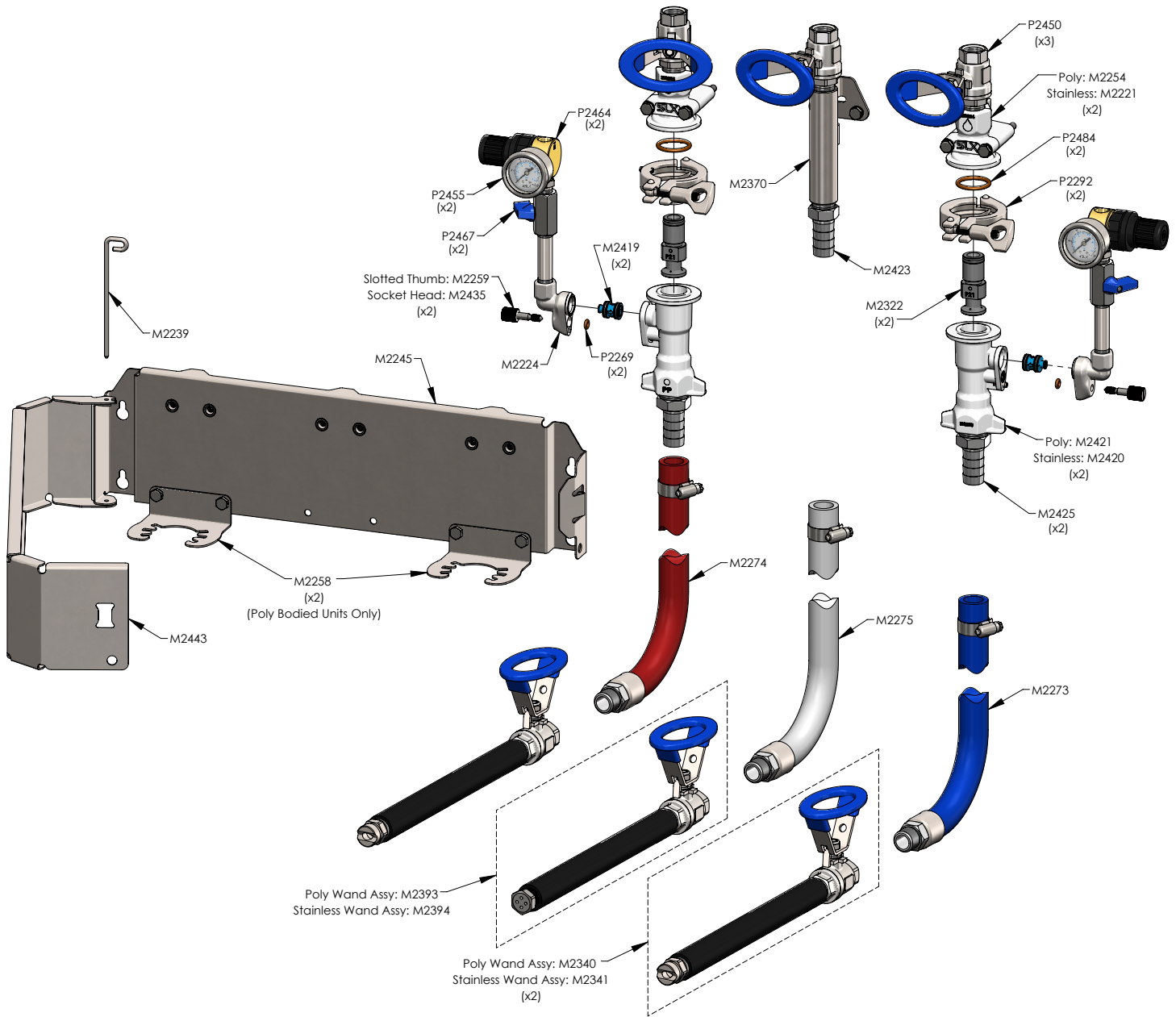

Purchase Replacement Parts:



USER MANUAL: SLX-MS3-PF-RN-PF

READ ALL INSTRUCTIONS BEFORE OPERATING EQUIPMENT



Parts Call-Out

NO.	DESCRIPTION
M2221	SLX UPPER BODY, TYPE-P, SS
M2224	SLX CHECK ELBOW, 1/4 FNPT, SS
M2239	SLX HINGE PIN V2.1
M2245	SLX CLAMSHELL BACKPLATE SIZE 3
M2254	SLX UPPER BODY, TYPE-P, PP
M2258	SLX LOWER SUPPORT BRACKET
M2259	SLX THUMB SCREW
M2273	HOSE ASSEMBLY, 3/4" X 50', PVC, BLUE, 1/2" MNPT ONE END
M2274	HOSE ASSEMBLY, 3/4" X 50', PVC, RED, 1/2" MNPT ONE END
M2275	HOSE ASSEMBLY, 3/4" X 50', PVC, WHITE, 1/2" MNPT ONE END
M2322	SLX INSERT ASSEMBLY, P21, W/ AFLAS SEALS
M2340	SLX WAND ASSEMBLY, 1/2" BALL VALVE, 50250 NOZZLE, 10" PP WAND
M2341	SLX WAND ASSEMBLY, 1/2" BALL VALVE, 50250 NOZZLE, 10" SS WAND
M2370	SLX RINSE WELDMENT
M2393	SLX WAND ASSEMBLY, 1/2" BALL VALVE, 4-HOLE RINSE NOZZLE, 10" PP WAND
M2394	SLX WAND ASSEMBLY, 1/2" BALL VALVE, 4-HOLE RINSE NOZZLE, 10" SS WAND
M2419	SLX CHECK VALVE, BALL TYPE, AFLAS SEALS, HASTELLOY SPRING, 0.5LB
M2420	SLX LOWER BODY (M2222), TYPE-F, SS, WITH PIN AND MESH
M2421	SLX LOWER BODY (M2255), TYPE-F, PP, WITH PIN AND MESH
M2423	PIPE ADAPTER, HOSE BARB, 1/2" NPT X 3/4" BARB, 316SS, 150 PSI
M2425	PIPE ADAPTER, HOSE BARB, 3/4" NPT X 3/4" BARB, 316SS, 150 PSI
M2435	SLX SECURITY SCREW - SOCKET
M2443	SLX CLAMSHELL DOOR REPLACEMENT ASSEMBLY - TRIPLE
P2269	O-RING, -106, .109" X .380" OD, Viton, Brown
P2292	SANITARY FLANGE CLAMP 1-1/2" 304SS - TRI CLAMP
P2450	VALVE, BALL, MANUAL, 1/2" NPT FEMALE X 1/2" NPT MALE, OVAL HANDLE, 2-PIECE, FULL PORT, 316SS BODY, PTFE SEAT, 1000 PSI W.O.G.
P2455	GAUGE, PRESSURE, 1-1/2", 0-150psi, 1/8" NPT, SS CASE, BRASS CONNECTION, CENTER BACK MOUNT
P2464	REGULATOR, AIR, 1/4" NPT, COMPACT
P2467	VALVE, BALL, MANUAL, 1/4" NPT FEMALE X 1/4" NPT FEMALE, BLUE LEVER HANDLE, 316SS
P2484	O-RING, 27 x 3.5, VITON, BROWN



More Information

Please contact Clean Logix at:

(616)-438-9200 or sales@clean-logix.com