

**CAUTION!** Always use care and wear appropriate PPE when working with chemicals!

## 1 Install and Connect

- A. Mount SLX plate to wall
- B. Flush supply lines
- C. Connect supply lines:
  - Compressed air from main timed controller unit (3/8" quick fit)
  - Pump supply (1/2" NPT)
- D. Connect discharge hose to spreader nozzle and hose barb on foamer
- E. Mount the spreader nozzle to wall near door
  - **P14:** 4.5" height
  - **P21 or P46:** 5-6" height

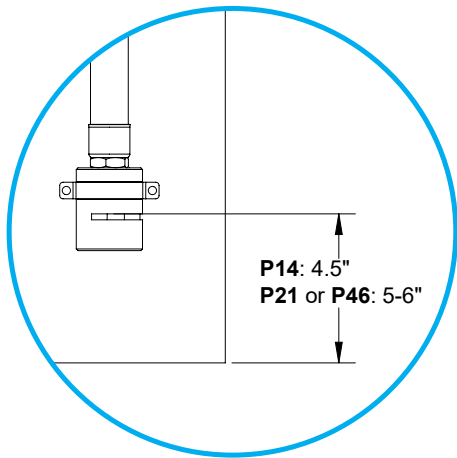

## Example Installation

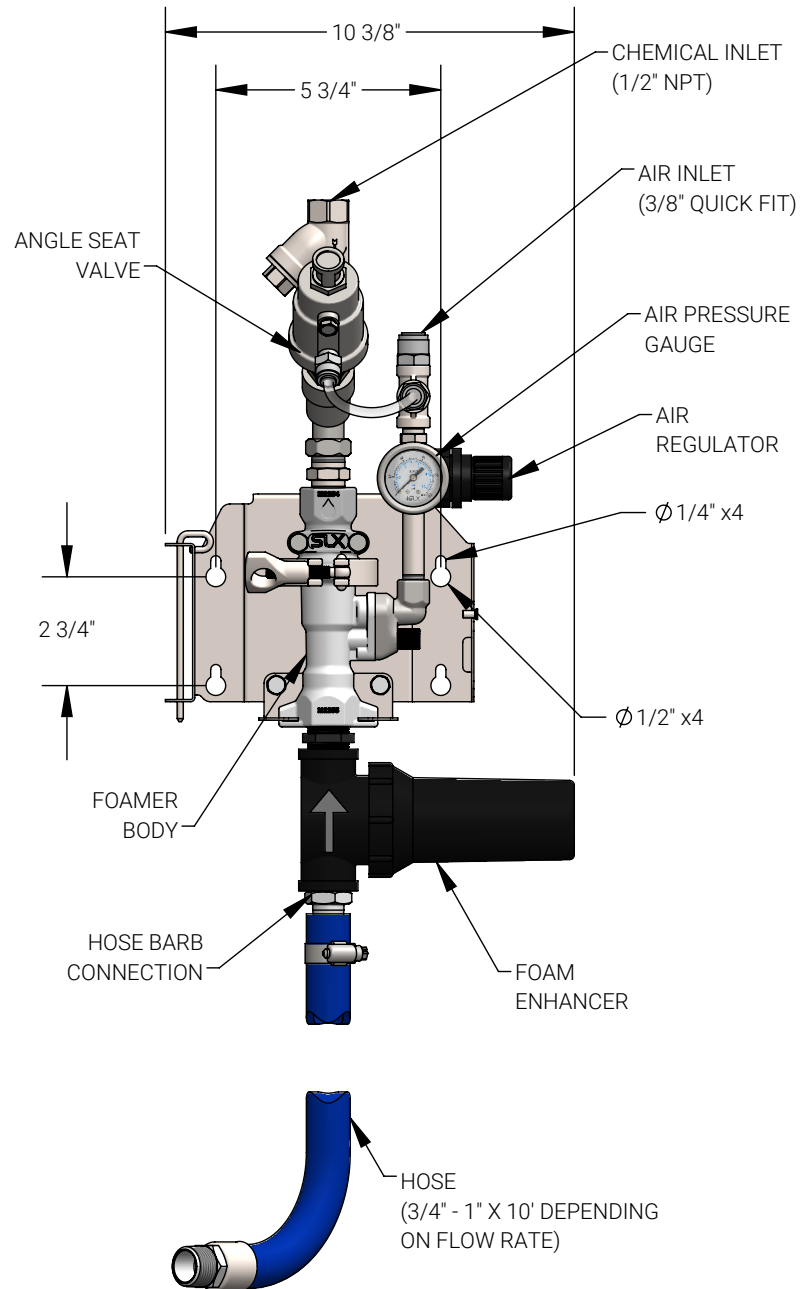

## 2 Operation

- A. Engage water and air supply
- B. Activate main controller system (see user manual for more information)
- C. Observe foam consistency - adjust air pressure as needed (min. pump supply pressure 35 PSI)

Parts will vary depending on model configuration.  
Please consult User Manual or contact us for more details.

Purchase Replacement Parts:



View User Manual for  
More Details:

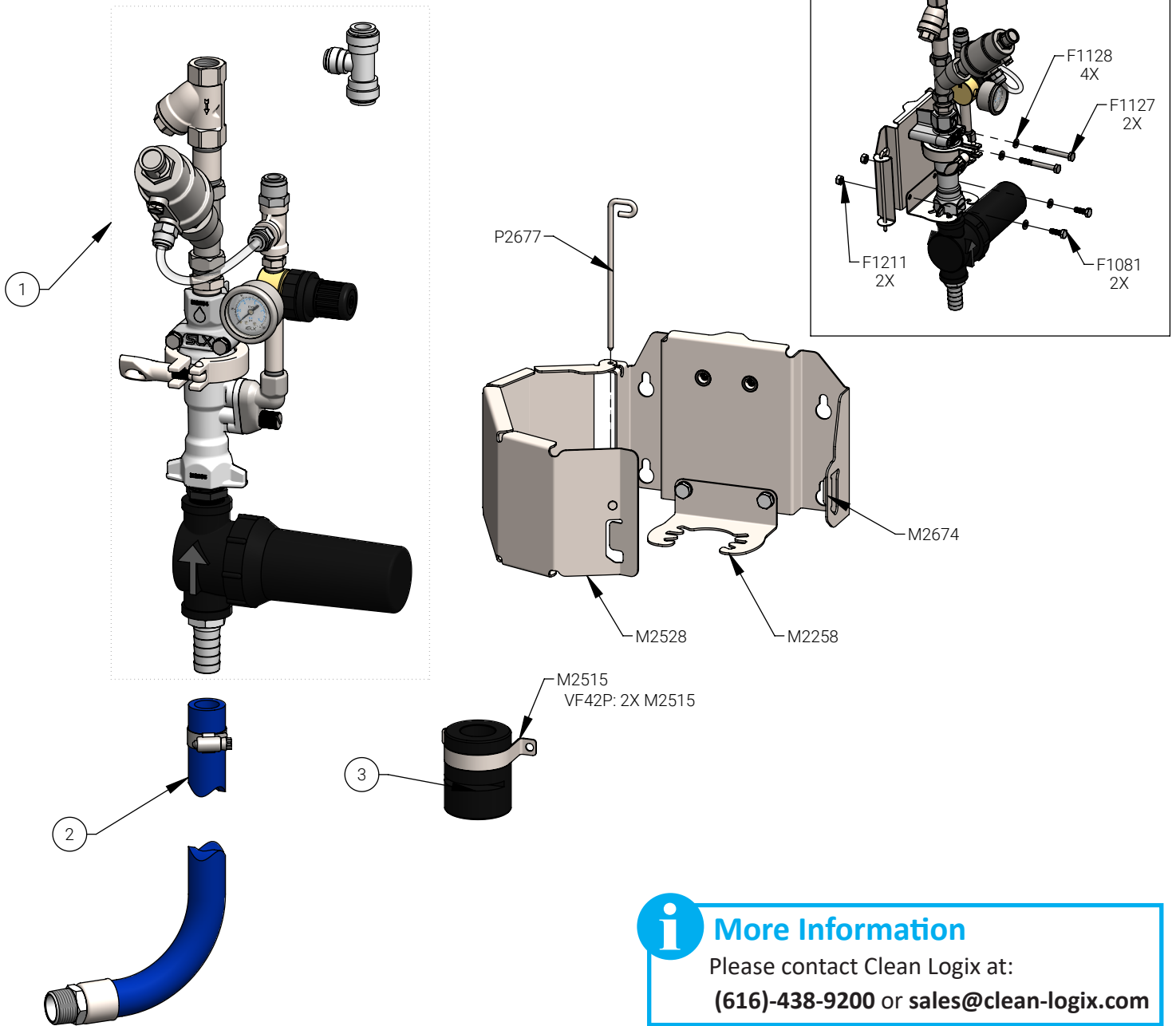

**i More Information**  
Please contact Clean Logix at:  
**(616)-438-9200** or [sales@clean-logix.com](mailto:sales@clean-logix.com)

Insert Size	Flow Rate GPM @ 40 PSI	(1) Foamer Stack Assembly	(2) Hose Assembly	(3) Nozzle #
P14	1.4	M2748	M2693	M2512
P21	2.1	M2749	M2692	M2513
P46	4.6	M2750	M2692	M2514