



USER MANUAL

MODEL:

SLX-BP-RN-VF

BOOSTED VENTURI RINSE & FOAM - MULTI STATION

English (Original Instructions)

Updated: 02/10/23





Table of Contents

System Requirements	03
Installation	04
Dilution	05
Operation	06
General Use	08
Maintenance	10
Troubleshooting	11
Parts Call Out	16

General Precautions

- For proper performance **do not** substitute nozzle or alter the diameter or length of the included hose.
- **Never** point the at another individual or electrical devices. Always direct the discharge away.
- **Do not** add a ball valve to the foamer outlet or kink the hose to stop discharge of foam.
- **Never** leave water or air supply inlet ball valves on when unit is not in use.
- **Never** mix chemicals without consulting the chemical manufacturer first.
- Manufacturer assumes no liability for the use or misuse of this unit or chemical compatibility.
- Specifications and parts are subject to change without notice.



Safety Warning



- All personnel servicing this unit must be familiar with the information contained in this manual. Follow all installation and maintenance instructions.
- Follow safety instructions of chemical manufacturer (SDS).
- Wear proper PPE when working with chemicals (gloves, safety glasses, face shield, etc.)
- Always follow plant and OSHA guidelines.
- Avoid contact of chemicals with skin and eyes. If contact occurs, see SDS sheet for further first aid measures.
- Follow all local codes for backflow prevention when connecting to a potable water supply.
- **WARNING: Severe damage to your facility, or contamination of your water supply, can occur without proper backflow prevention.**

PROTECT THE ENVIRONMENT

Please dispose of packaging materials, old machine components, and hazardous fluids in an environmentally safe way according to local waste disposal regulations.



Always remember to recycle.



Overview

The SLX Boosted Rinse & Foam multi-station provides an all in one set up to quickly and effectively foam and rinse off equipment using boosted water pressure (125-350 PSI) from one location using two discharge hoses.

This medium volume decentralized cleaning system uses a water driven venturi effect to dilute concentrated chemistry or cleaning solution into the foamer. Both the foamer and rinse station are securely mounted onto a stainless-steel wall bracket for easy installation.

Requirements

- Water Pressure: 125 - 350 PSI

NOTE: A back flow preventer must be installed in the water supply to this unit, per local codes.

- Max Temperature: 140°F
- Air Pressure: 40 PSI recommended
- Chemical compatibility: Chemical products used with this equipment must be formulated for this type of application and compatible with unit materials (see specifications).

NOTE: For more information on chemical compatibility consult the chemical manufacturer.

Specifications

- Materials of Construction:
 - Body: 304SS
 - Enclosure: 304SS
 - Wetted Parts: PVC, Polypropylene, AFLAS, and Stainless Steel
- Weight:
 - System with enclosure: 20 lbs.
 - Hose Assembly: 15 - 18 lbs. (each)
 - Spray wand: 0.47-1.24 lbs. (each)
- Dimensions: 16" x 4.75" x 6"

Insert #	Foam Flow Rate (GPM)	Rinse Water Flow Rate (GPM)	Hose Size (OD x L)	Spray Nozzle
V28	2.8	13.1	3/4" x 50'	65300

Flow rates and coverage time may vary depending on supply pressure, metering tip size, and chemistries. Always test prior to normal operation to ensure facility requirements are met for cleaning procedures.



More Information

Please contact Clean Logix at:
(616)-438-9200 or **sales@clean-logix.com**

USER MANUAL: SLX-BP-MS2-RN-VF

READ ALL INSTRUCTIONS BEFORE OPERATING EQUIPMENT



Installation

1. Mount the enclosure to the wall.
2. Flush air and water supply lines to ensure they are flowing properly and free of debris.
3. Install backflow prevention per local codes.
4. Connect water to water inlet at top of unit (3/4" NPT)
5. Connect air to air inlet (1/4" NPT) on foamer
6. Connect discharge hoses and spray wands to the bottom hose barbs and secure with hose clamps.

NOTE: Air filter recommended

WARNING

Backflow prevention required - consult local codes.

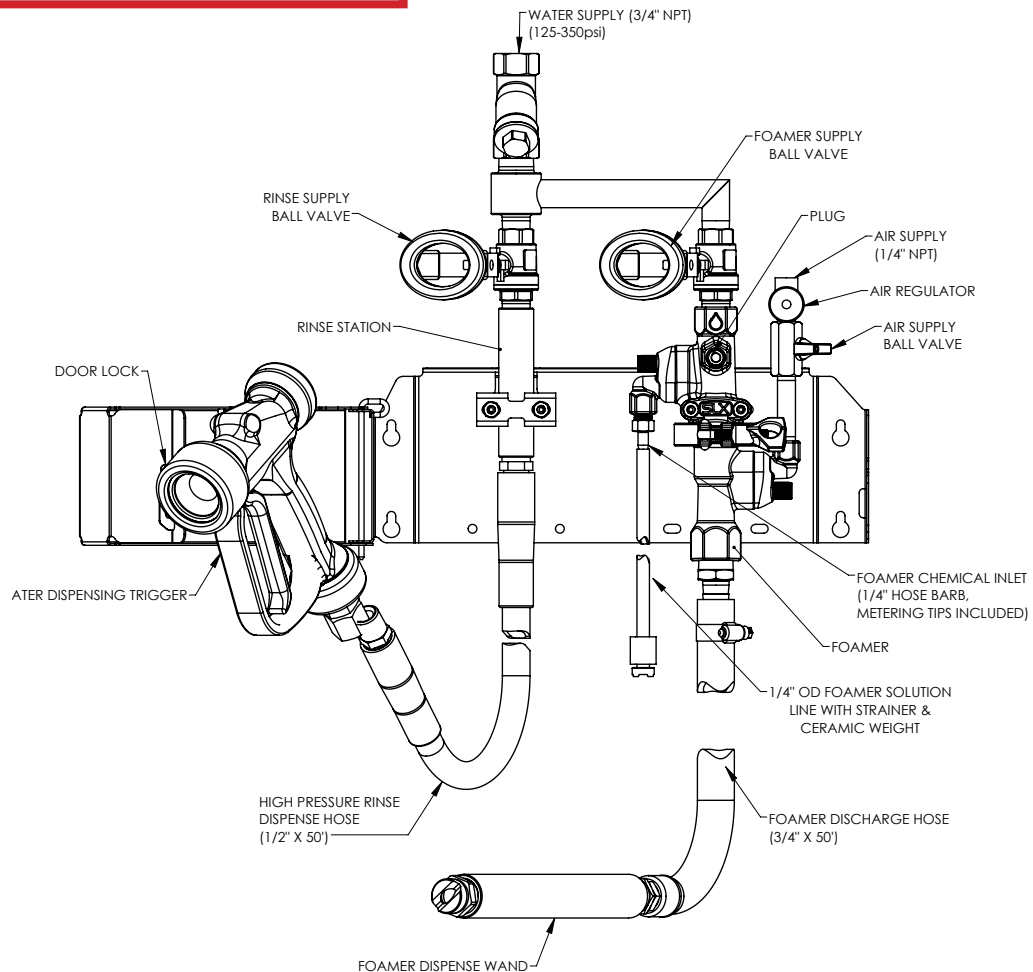
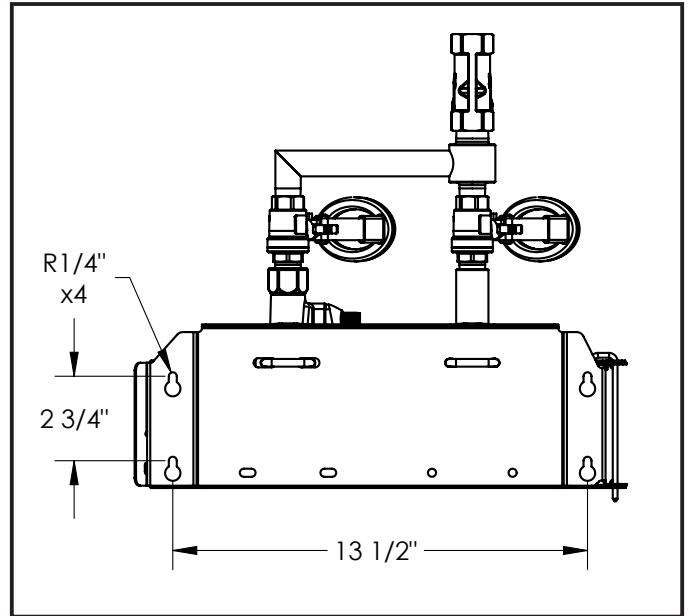

Dilution

Metering Tips

1. Place chemical container below unit.
2. Using the included metering tips, identify which tip is appropriate for your dilution ratio for each system

NOTE: Review dilution recommendations for the chemistry being used. GPM's calculated at 40 PSI water pressure. For different pressure estimates use following formula:

$$\text{Dilution Ratio} = \frac{(\text{GPM} \times 128)}{\text{Oz/Gal}}$$

3. Thread metering tip into hose barb on chemical inlet to install. [Fig 5.1]
4. Connect suction line to hose barb.
5. Connect suction line in chemical container (suction line with ceramic weight and strainer included for this purpose).

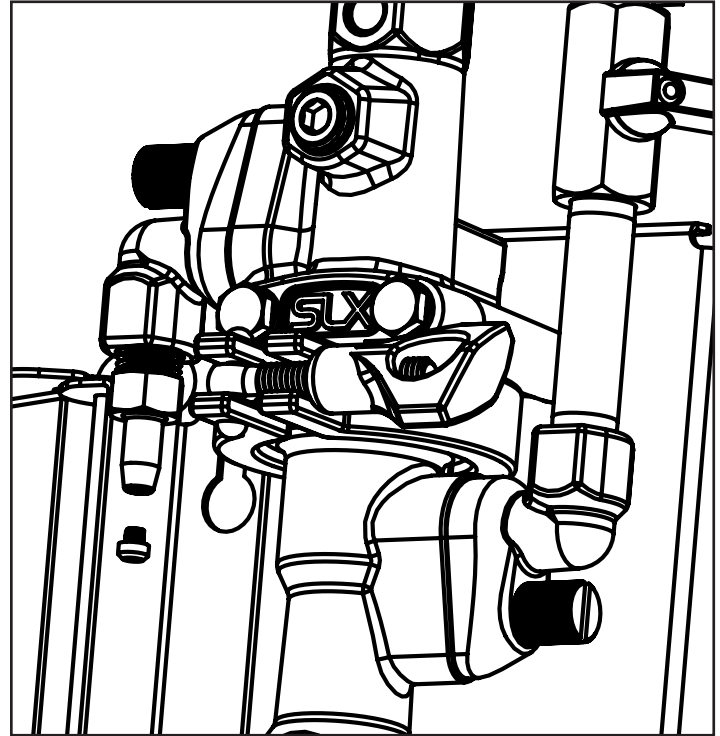

Fig. 5.1: Metering tip and hose barb

Metering Tip Dilution Ratios

Color	Oz/Gal	V28
Copper	0.56	640:1
Pumpkin	0.73	491:1
Burgundy	0.90	398:1
Lime	1.28	280:1
Orange	1.70	211:1
Turquoise	2.15	167:1
Pink	2.93	122:1
Corn Yellow	3.84	93:1
Dark Green	4.88	73:1
Orange	5.77	62:1
Gray	6.01	60:1
Light Green	7.01	51:1
Med. Green	8.06	44:1

Metering Tip Calculator
Mobile App:



Color	Oz/Gal	V28
Clear Pink	9.43	38:1
Yellow Green	11.50	31:1
Maroon	11.93	30:1
Pale Pink	13.87	26:1
Light Blue	15.14	24:1
Dark Purple	17.88	20:1
Navy Blue	25.36	14:1
Clear Aqua	28.60	13:1
Black	50.00	7.2:1

NOTE: Dilution ratios may vary depending. Always test chemical dilution prior to normal operation.

Operation

Initial Use

When operating the foamer for the first time some alterations may need to be made to produce the desired foam quality and ensure the unit is drawing chemistry as intended.

1. Ensure foamer is properly connected and the water and air supply valves are closed [Fig. 6.1]
 2. Take hold of the spray wand.
 3. Fully open water valve.
 - The spray wand will begin discharging water.
 - Chemical will be drawn up the suction line and introduced to the fluid path.
 4. Ensure water pressure is above 125 PSI
 5. Fully open air valve.
 - There will be a kick of pressure as the spray wand recoils from the air pressure.
 6. Foam will begin to initiate.
 - This may appear uneven at first but as the air and water pressure stabilize the quality of the foam will become more uniform.
 7. To alter foam consistency adjust the air pressure [Fig. 6.2]:
 - **Dryer Foam** - Increase air pressure (turn dial clockwise).
 - **Wetter Foam** - Decrease air pressure (turn dial counter-clockwise).
8. Check foam quality and dilution amount per facility standards.
9. Metering tip size may need to be changed if foam quality or dilution ratio is still not adequate.

NOTE: Always keep air pressure BELOW water pressure!

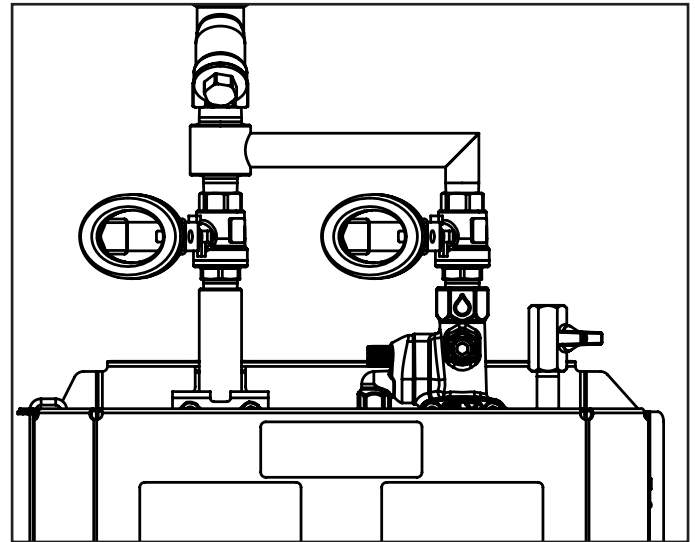

Fig. 6.1: Water and air supply ball valves closed.

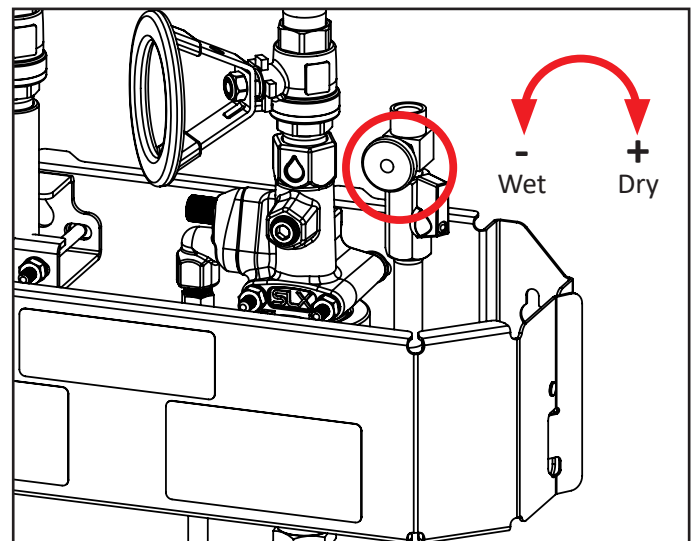
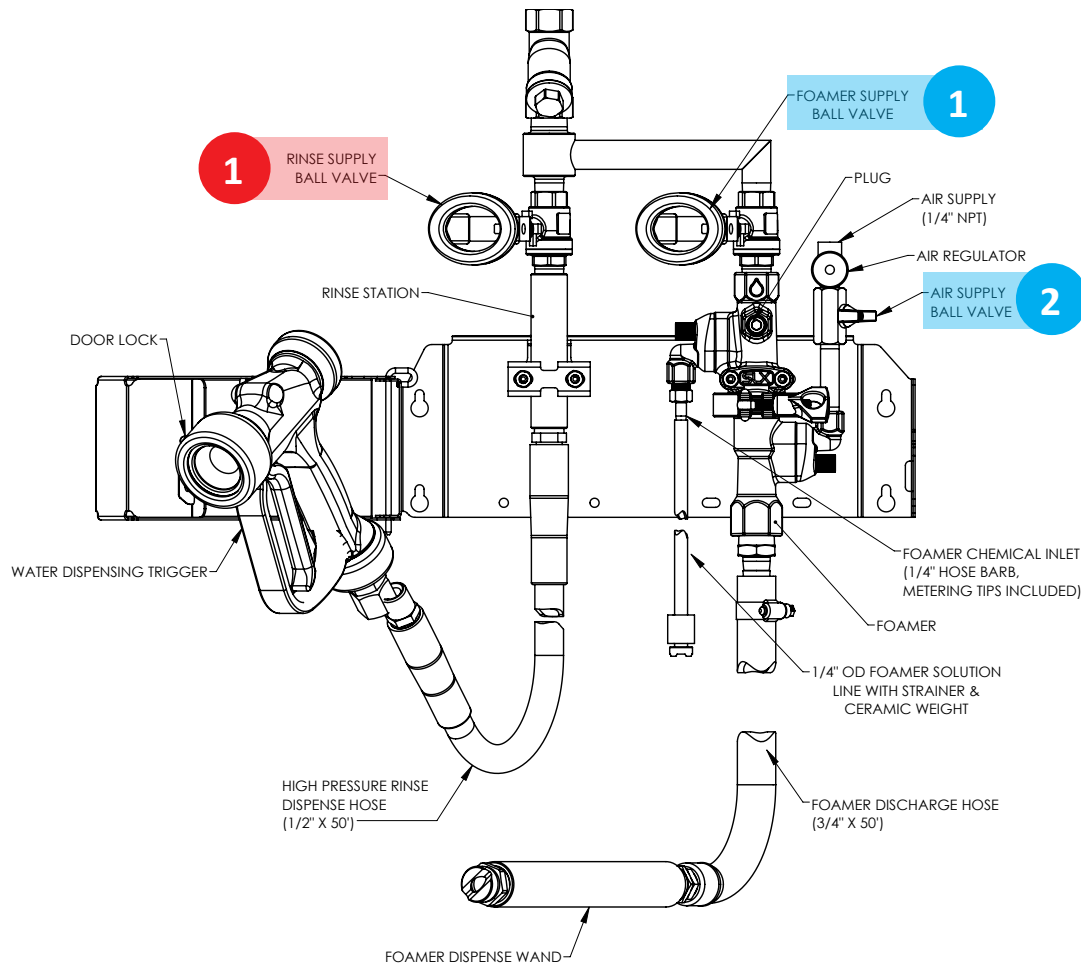

Fig. 6.2: Air pressure adjustment for foamers.

Operation (cont.)

Normal Use

1. Ensure system is properly connected and the water and air supply [Foamer] valves are closed
2. Take hold of the spray wand for the intended system
3. Fully open water valve.
 - [Foamer] The spray wand will begin discharging water.
4. [Foamer] Fully open air valve.
 - There will be a kick of pressure as the spray wand recoils from the air pressure.
 - Foam will begin to initiate - this may appear uneven at first but as the air and water pressure stabilize the quality of the foam will become more uniform.
5. [Foamer] Apply foam from bottom to top, ensuring even coating. Rinse before foam dries to avoid streaking.
6. Rinse from top to bottom before foam dries.
7. When complete, turn off supply lines.
8. Pull trigger on rinse gun and exhaust pressure completely.
9. Rinse hose(s) as necessary.
10. Store hoses depressurized, with the ball valve open and coiled properly to prevent kinks or damage.



General Use

Removing Venturi Insert

1. Ensure supply lines are off and system is depressurized.

WARNING

Depressurize system prior to servicing! Always wear appropriate personal protective equipment (PPE) when handling chemical per SDS recommendations.

2. Open the enclosure door.
3. Loosen the tri-clamp fitting to disconnect the upper and lower body. [Fig 8.1]

NOTE: Supply lines and discharge hose can remain connected during this process. Ensure there is adequate hose/tubing length for maneuverability.

4. Pull the lower body down, away from the upper section.

WARNING

An o-ring is positioned between the upper and lower bodies. Ensure it is not lost during servicing.

5. With the bottom half removed the venturi insert can be accessed; pull straight down to remove.
 - Force may be required due to o-rings and/or chemical build-up.
 - A screwdriver can be used to pry the insert out if necessary. [Fig. 8.2]
6. The insert can be cleaned using warm water or descaling acid compatible with PVC.

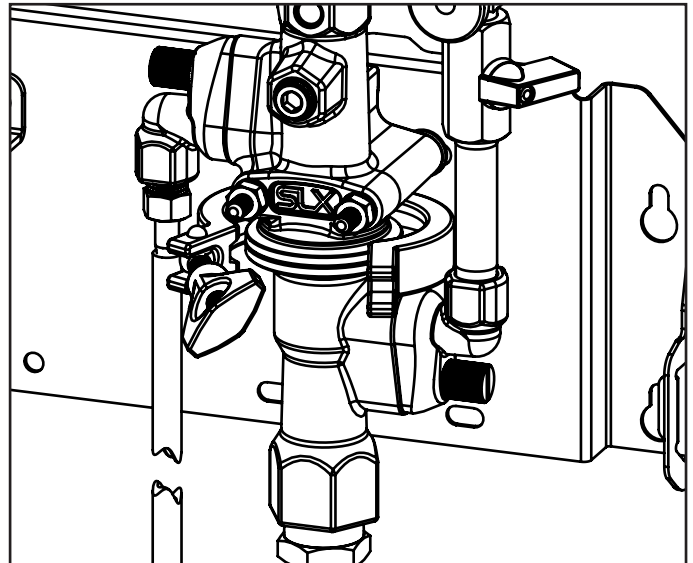

Fig. 8.1: Tri-clamp open

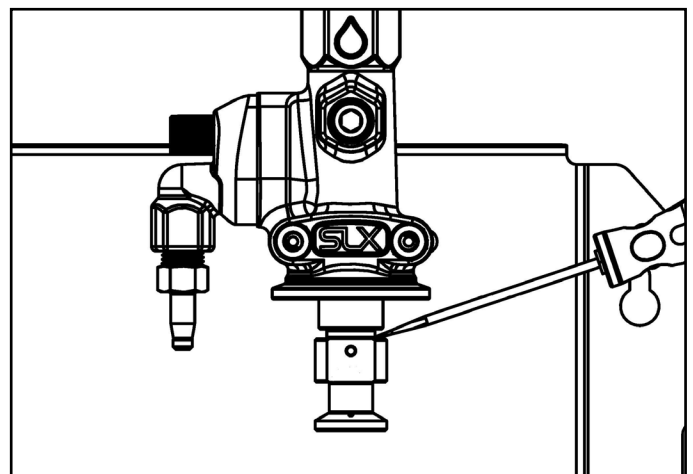

Fig. 8.2: Venturi insert removal using screwdriver

General Use (cont.)

Removing Venturi Insert (cont.)

7. Replace insert when clean or with a new version by sliding it back into the upper body, o-ring section first. [Fig 9.1]

WARNING

Ensure o-ring is positioned between the upper and lower bodies and is seated properly. Failure to do so may result in leaks or improper performance.

8. Reconnect the lower body to the upper section.
9. Place the tri-clamp around the lip where the two halves meet, tighten in place until secure.
10. Ensure all connection points are secure.
11. Close enclosure door and lock if necessary.
12. Follow initial setup procedures to test insert and foam/spray quality before resuming normal operation.

Removing Check Valve

1. Ensure supply lines are off and system is depressurized.
2. Open the enclosure door
3. Loosen the thumb screw on the elbow by hand or using a flathead screwdriver. [Fig 9.2]
4. Pull the elbow away from the main body.
5. The check valve will be seated either inside of the elbow or the body. Grab it and pull to remove. [Fig 9.3]
6. Clean or replace if damaged.
7. To reinsert, orient the check valve with the arrow pointing towards the main body and press into place.
8. Reattach the elbow and tighten the thumb screw until secure.

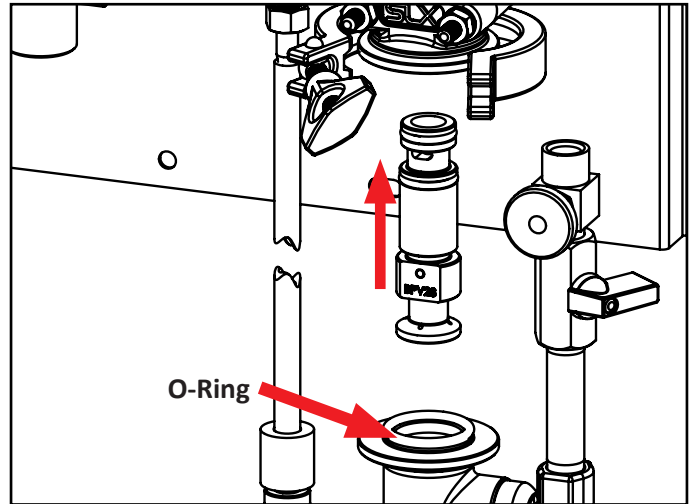

Fig. 9.1: Replacing venturi insert and foamer body

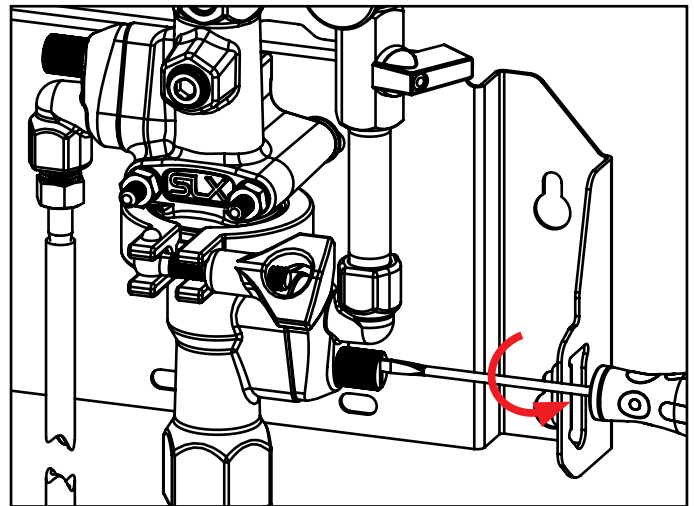

Fig. 9.2: Loosening thumb screw on elbow (foamer air inlet)

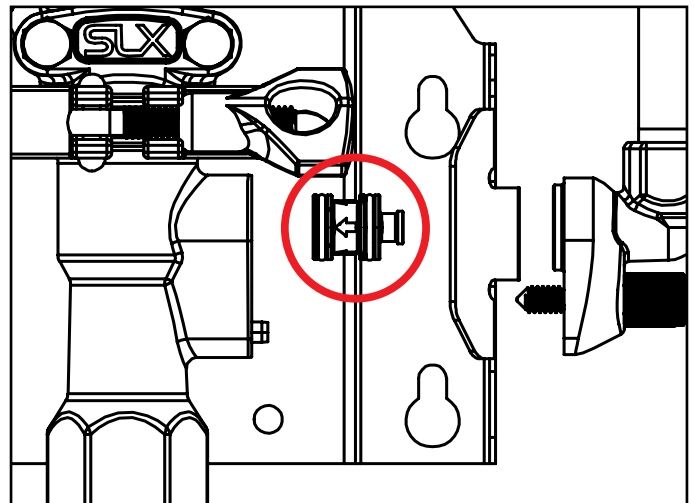

Fig. 9.3: SLX Check Valve at air inlet (correct orientation)

Maintenance

The following maintenance procedures are recommended for normal use. Units which see a high amount of use should be inspected more frequently.

WARNING

Depressurize system prior to servicing! Always wear appropriate personal protective equipment (PPE) when handling chemical per SDS recommendations.

Daily:

- Check condition of hose (damage or leaks)
 - Replace as necessary.
- Ensure air and water lines are not receiving backflow of chemistry.
 - Ensure check valves are operating properly, replace as necessary.
- Verify ball valves are operating properly.
 - Replace as necessary.

Weekly:

- Ensure metering tip is free of clogs
 - Remove from chemical inlet and clean with water.
- Ensure tri-clamp is secure and bodies are sealed
 - Verify o-ring is seated properly and is not damaged. Replace as necessary.
 - Check that tri-clamp is seated properly and tighten till secure.

Monthly

- Verify check valves are operating properly
 - Remove and ensure spring is functioning properly. Replace as necessary.
- Check venturi insert for clogs and debris.
 - Remove and inspect - if clogged or scale has built up clean with water or de-scaling acid compatible with PVC.
- Check o-rings on inserts and check valves.
 - Remove and replace as necessary.
 - O-rings can be purchased individually or pre-installed as complete check valve or insert assemblies.

Annually

- Replace discharge hose (and wand if necessary)
- Replace insert, check valves, regulators, and gauges



More Information

Please contact Clean Logix at:

(616)-438-9200 or **sales@clean-logix.com**



Troubleshooting

System surges, bucks, and/or recoils

	Cause	Solution
Start-up	Air pressure too high	Lower the air pressure using the included regulator slowly until output stabilizes.
	Water pressure or water volume too low/inlet piping too small causing poor chemical pick up	Increase water pressure or water volume.
	Inlet or discharge ball valve is not completely open	Completely open the ball valves.
	Not enough chemistry is being diluted	Install larger metering tip to use more chemistry
	Improper chemical	Ensure product is recommended for foaming and the intended application.
	Chemical supply is empty or suction line is not fully submerged	Immerse tube or replenish chemical in container.
	Discharge hose too long or wrong size or kinked	Straighten the hose or replace hose with correct size and length.
	Nozzle size too small	Replace nozzle with correct size.
	Oil or lubricant is present in airline	Use only clean, dry air.
Extended Use	Foamer insert is clogged	Open foamer body and check for debris or obstructions. Clean as necessary with water or air.
	Chemical strainer or metering tip partially blocked	Clean or replace chemical strainer and/or metering tip.
	Chemical tube stretched out or pin hole/cut in chemical tube sucking air.	Cut off end of tube or replace tube.
	Vacuum leak in chemical pick-up connections	Tighten the connection.
	Improper air pressure	Check regulator settings. Clean or replace as necessary.
	Chemical check valve stuck or failed	Clean or replace.
	Hard water scale or chemical build-up may have formed in the foamer body causing poor or no chemical pick-up	Open foamer body and check for build-up. Remove and clean with water or descaling acid (insert is PVC). Replace as necessary.
	Needle valve is clogged and not allowing enough air	Clean or replace.

For Technical Support:





Troubleshooting

Venturi will not draw chemical

	Cause	Solution
Start-up	Air pressure too high	Lower the air pressure using the included regulator slowly until output stabilizes.
	Inlet or discharge ball valve is not completely open	Completely open the ball valves.
	Not enough chemistry is being diluted	Install larger metering tip to use more chemistry.
	Chemical supply is empty or suction line is not fully submerged	Immerse tube or replenish.
	Discharge hose too long or wrong size or kinked	Straighten the hose or replace hose with correct size and length (see system specifications based on insert size)
	Nozzle size too small	Replace nozzle with correct size (see system specifications based on insert size).
Extended Use	Foamer insert is clogged	Open foamer body and check for debris or obstructions. Clean as necessary with water or air.
	Chemical strainer or metering tip partially blocked	Clean or replace chemical strainer and/or metering tip.
	Chemical tube stretched out or pin hole/cut in chemical tube sucking air.	Cut off end of tube or replace tube.
	Vacuum leak in chemical pick-up connections	Tighten the connection.
	Improper air pressure	Check regulator settings. Clean or replace as necessary.
	Chemical check valve stuck or failed	Clean or replace.
	Hard water scale or chemical build-up may have formed in the foamer body causing poor or no chemical pick-up	Open foamer body and check for build-up. Remove and clean with water or descaling acid (insert is PVC). Replace as necessary.
	Needle valve is clogged and not allowing enough air	Clean or replace.

For Technical Support:





Troubleshooting

Foam is too wet

	Cause	Solution
Start-up	Water pressure or water volume too low/inlet piping too small causing poor chemical pick up	Increase water pressure or water volume.
	Inlet or discharge ball valve is not completely open	Completely open the ball valves.
	Chemical ball valve not open (2-way only)	Open chemical ball valve.
	Not enough chemistry is being diluted	Install larger metering tip to use more chemistry.
	Improper chemical	Ensure product is recommended for foaming and the application.
	Chemical supply is empty or suction line is not fully submerged	Immerse tube or replenish.
	Discharge hose too long or wrong size or kinked	Straighten the hose or replace hose with correct size and length.
	Nozzle size too small	Replace nozzle with correct size.
	Oil or lubricant is present in airline	Use only clean, dry air.
Extended Use	Chemical strainer or metering tip partially blocked	Clean or replace chemical strainer and/or metering tip.
	Chemical tube stretched out or pin hole/cut in chemical tube sucking air	Cut off end of tube or replace tube.
	Vacuum leak in chemical pick-up connections	Tighten the connection.
	Improper air pressure	Check regulator settings. Clean or replace as necessary.
	Chemical check valve stuck or failed	Clean or replace.
	Hard water scale or chemical build-up may have formed in the foamer body causing poor or no chemical pick-up	Open foamer body and check for build-up. Remove and clean with water or descaling acid (insert is PVC). Replace as necessary.

For Technical Support:





Troubleshooting

Foamer does not clean properly or Foam is too dry

Cause	Solution
Air pressure too high	Lower the air pressure using the included regulator slowly until output stabilizes.
Not enough chemistry is being diluted	Install larger metering tip to use more chemistry
Improper chemical	Ensure product is recommended for foaming and the application.
Hose may be damaged or kinked.	Straighten the hose, replace if damaged.
Incorrect discharge hose, wand, and/or nozzle size.	Verify size and replace if necessary with correct size and length (see system specifications based on insert size)

Venturi is using too much chemistry

Cause	Solution
No metering tip installed or metering tip too large	Install smaller metering tip.

For Technical Support:





Troubleshooting

Water and/or chemistry is backing up into air supply line

Cause	Solution
Air check valve failed	Clean and replace as necessary

Water is backing up into chemical container

Cause	Solution
Chemical check valve stuck or failed	Clean or replace.

Air and/or chemistry is backing up into water supply line

Cause	Solution
Inlet ball valve left on when not in use	Turn off ball valve

For Technical Support:



USER MANUAL: SLX-BP-MS2-RN-VF

READ ALL INSTRUCTIONS BEFORE OPERATING EQUIPMENT



Parts Call-Out

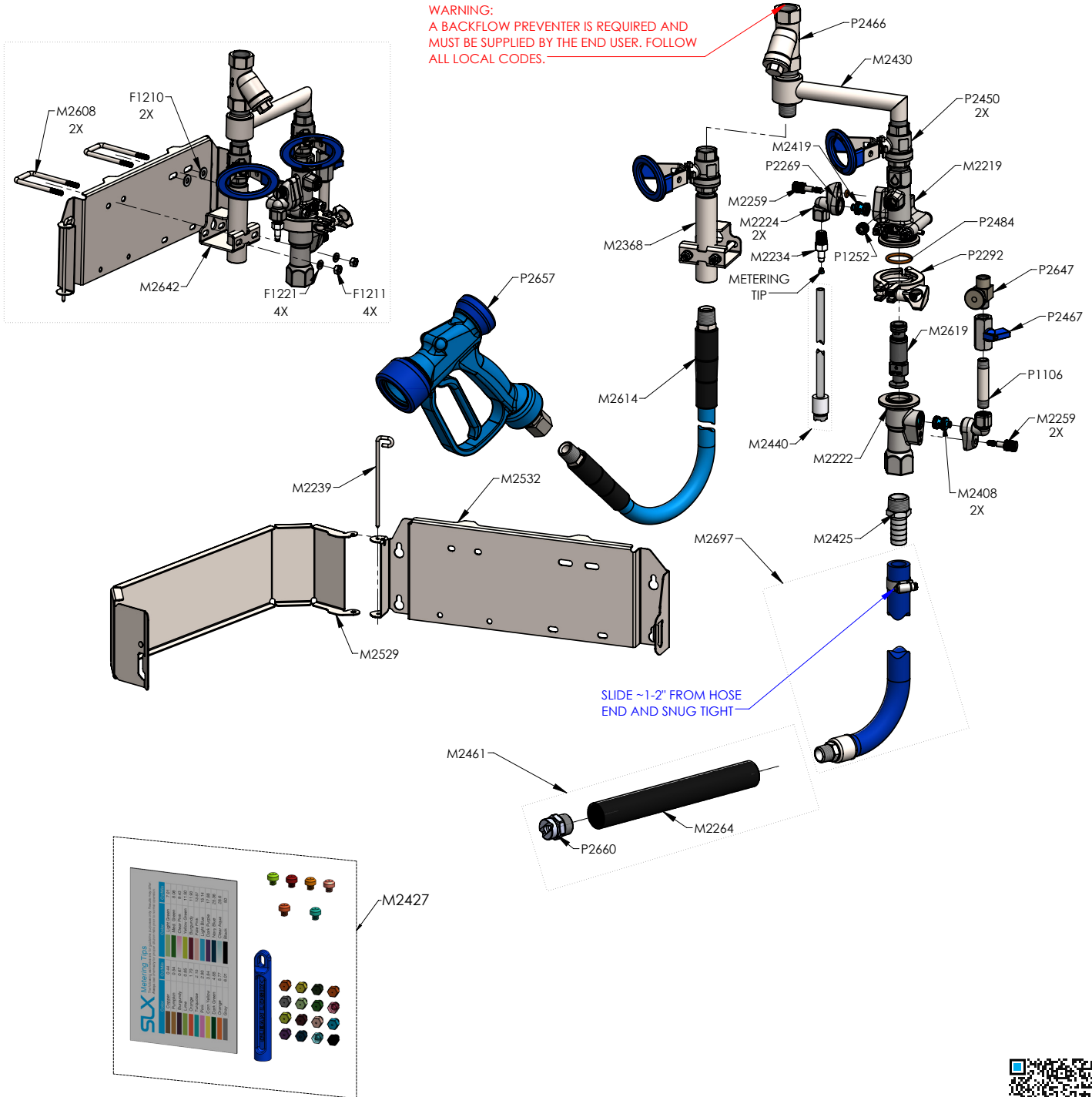

Purchase Replacement Parts:



USER MANUAL: SLX-BP-MS2-RN-VF

READ ALL INSTRUCTIONS BEFORE OPERATING EQUIPMENT



Parts Call-Out

PART NUMBER	DESCRIPTION
F1210	WASHER 1/4 316SS
F1211	NUT 1/4-20 316SS
F1221	WASHER SPLIT LOCK 1/4 316SS
M2219	SLX UPPER BODY, TYPE-1V, SS
M2224	SLX CHECK ELBOW, 1/4 FNPT, SS
M2232	SLX METERING BARB 1/4" NPT X 1/4" BARB
M2239	SLX HINGE PIN V2.1
M2259	SLX THUMB SCREW
M2368	SLX RINSE COUPLER
M2419	SLX CHECK VALVE, BALL TYPE, AFLAS SEALS, HASTELLOY SPRING, 0.5LB
M2420	SLX LOWER BODY (M2222), TYPE-F, SS, WITH PIN AND MESH
M2425	PIPE ADAPTER, HOSE BARB, 3/4" NPT X 3/4" BARB, 316SS, 150 PSI
M2427	SLX METERING TIP FULL KIT - 22 TIPS AND DRIVER
M2430	SLX MANIFOLD DUAL - WELDED
M2440	SLX SUCTION LINE ASSEMBLY 1/4" X 6' WITH STRAINER AND WEIGHT
M2442	SLX CLAMSHELL DOOR REPLACEMENT ASSEMBLY - TRIPLE
M2529	SLX CLAMSHELL DOOR V4.2 SIZE 2
M2532	SLX CLAMSHELL BACKPLATE V4.2 SIZE 2
M2608	SLX U-BOLT, 3.375" x 1.75" x 1/4"-20 - 0.75" Thread Length, 304SS
M2619	SLX INSERT ASSEMBLY, BPV28
M2641	SLX BP WAND ASSEMBLY, 3/4" NPT VEE NOZZLE NOZZLE, 10" PP WAND
M2642	BRACKET, SLX RINSE STATION, C-BRACKET
M2697	HOSE ASSEMBLY, 3/4" X 50', BLUE, 3/4" MNPT ONE END
P1106	PIPE NIPPLE, 1/4" NPT X 2-1/2" LONG, 316SS, 150 PSI
P1252	PIPE PLUG 1/4" NPT SOCKET HD SS
P2269	O-RING 106 3/32 x 3/16 ID x 3/8 OD EPDM
P2292	SANITARY FLANGE CLAMP 1-1/2" 304SS - TRI CLAMP
P2450	VALVE, BALL, MANUAL, 1/2" NPT X 1/2" NPT, 316SS BODY, PTFE SEAT, 1000 PSI W.O.G.
P2466	STRAINER, Y, 3/4" NPT, 316SS, 140 MESH (100 MICRON), 800 PSI WOG
P2467	VALVE, BALL, MANUAL, 1/4" NPT FEMALE X 1/4" NPT FEMALE, BLUE LEVER HANDLE, 316SS
P2484	O-RING, 27 x 3.5, VITON, BROWN
P2647	VALVE, NEEDLE, 1/4" NPT FEMALE TO 1/4" NPT MALE, ROUND KNOB, ENP
P2657	GUN, WASHDOWN, 350PSI, 16GPM, 1/2" NPT FEMALE SWIVEL INLET, ADJUSTBLE SPRAY, BLUE



More Information

Please contact Clean Logix at:

(616)-438-9200 or sales@clean-logix.com