



USER MANUAL

MODEL:

SLX-MS3-VS-RN-VA

VENTURI SANITIZE, RINSE, AIRLESS FOAM - MULTI STATION

English (Original Instructions)

Updated: 06/02/23





Table of Contents

System Requirements	03
Installation	04
Dilution	05
Operation	07
General Use	09
Maintenance	11
Troubleshooting	12
Parts Call Out	14

General Precautions

- For proper performance **do not** substitute nozzle or alter the diameter or length of the included hose.
- **Never** point the spray wand at another individual or electrical devices. Always direct the discharge away.
- For pressures over 100 PSI, remove the discharge valve or lower pressure.
- **Never** leave water or air supply inlet ball valves on when unit is not in use.
- **Never** mix chemicals without consulting the chemical manufacturer first.
- Manufacturer assumes no liability for the use or misuse of this unit or chemical compatibility.
- Specifications and parts are subject to change without notice.



Safety Warning



- All personnel servicing this unit must be familiar with the information contained in this manual. Follow all installation and maintenance instructions.
- Follow safety instructions of chemical manufacturer (SDS).
- Wear proper PPE when working with chemicals (gloves, safety glasses, face shield, etc.)
- Always follow plant and OSHA guidelines.
- Avoid contact of chemicals with skin and eyes. If contact occurs, see SDS sheet for further first aid measures.
- Follow all local codes for backflow prevention when connecting to a potable water supply.
- **WARNING: Severe damage to your facility, or contamination of your water supply, can occur without proper backflow prevention.**

PROTECT THE ENVIRONMENT

Please dispose of packaging materials, old machine components, and hazardous fluids in an environmentally safe way according to local waste disposal regulations.



Always remember to recycle.



Overview

The SLX Sanitize, Rinse & Airless Foam multi-station is the most complete, all-in-one set up for cleaning and sanitizing industrial processing equipment using standard water pressure (35-125 PSI) from one location with no compressed air. This low to medium volume decentralized sanitation system uses a water driven venturi effect to dilute concentrated cleaning solutions and sanitizers, independently, to foam and sanitizer proportioners. All three systems (sanitizer, rinse station and airless foamer) are all securely mounted onto a stainless-steel wall bracket for easy installation.

The included instructions apply to both polypropylene and stainless steel venturi foamers regardless of insert size. Model specific specifications will be identified as necessary.

Requirements

- Water Pressure: 35 - 125 PSI

NOTE: A back flow preventer must be installed in the water supply to this unit, per local codes.

- Max Temperature: 140°F
- Chemical compatibility: Chemical products used with this equipment must be formulated for this type of application and compatible with unit materials (see specifications).

NOTE: For more information on chemical compatibility consult the chemical manufacturer.

Specifications

- Materials of Construction:
 - Body: Polypropylene or Stainless Steel (dependent on model)
 - Enclosure: 304SS
 - Wetted Parts: PVC, Polypropylene, AFLAS, and Stainless Steel
- Weight:
 - System with enclosure: 19 - 22 lbs.
 - Hose Assembly: 10 - 17.5 lbs. (each)
 - Spray wand: 1.2 - 1.3 lbs. (each)
- Dimensions: 20" x 17³/₈" x 6"

NOTE: Weights will vary depending on model configuration and construction materials (i.e. stainless vs. polypropylene)

Station / Insert #	Water Flow Rate (GPM)	Hose Size (OD x L)	Spray Wand
Foamer V14	1.4	1/2" x 50'	M2516
Sanitizer V54	5.4	3/4" x 50'	M2336 M2337
Rinse	7.2	3/4" x 50'	M2393 M2394

Flow rates and coverage time may vary depending on supply pressure, metering tip size, and chemistries. Always test prior to normal operation to ensure facility requirements are met for cleaning procedures.



More Information

Please contact Clean Logix at:
(616)-438-9200 or **sales@clean-logix.com**

Installation

1. Mount the enclosure to the wall.
2. Flush water supply line To ensure it is flowing properly and free of debris.
3. Install backflow prevention per local codes.
4. Connect water to water inlet at top of unit (3/4" NPT)
5. Connect discharge hoses and spray wands to the bottom hose barbs and secure with hose clamps.

NOTE: Hose and wand sizes/types will vary. Consult system specifications to ensure the proper hose and wand are used for ideal performance.

WARNING

Backflow prevention required - consult local codes.

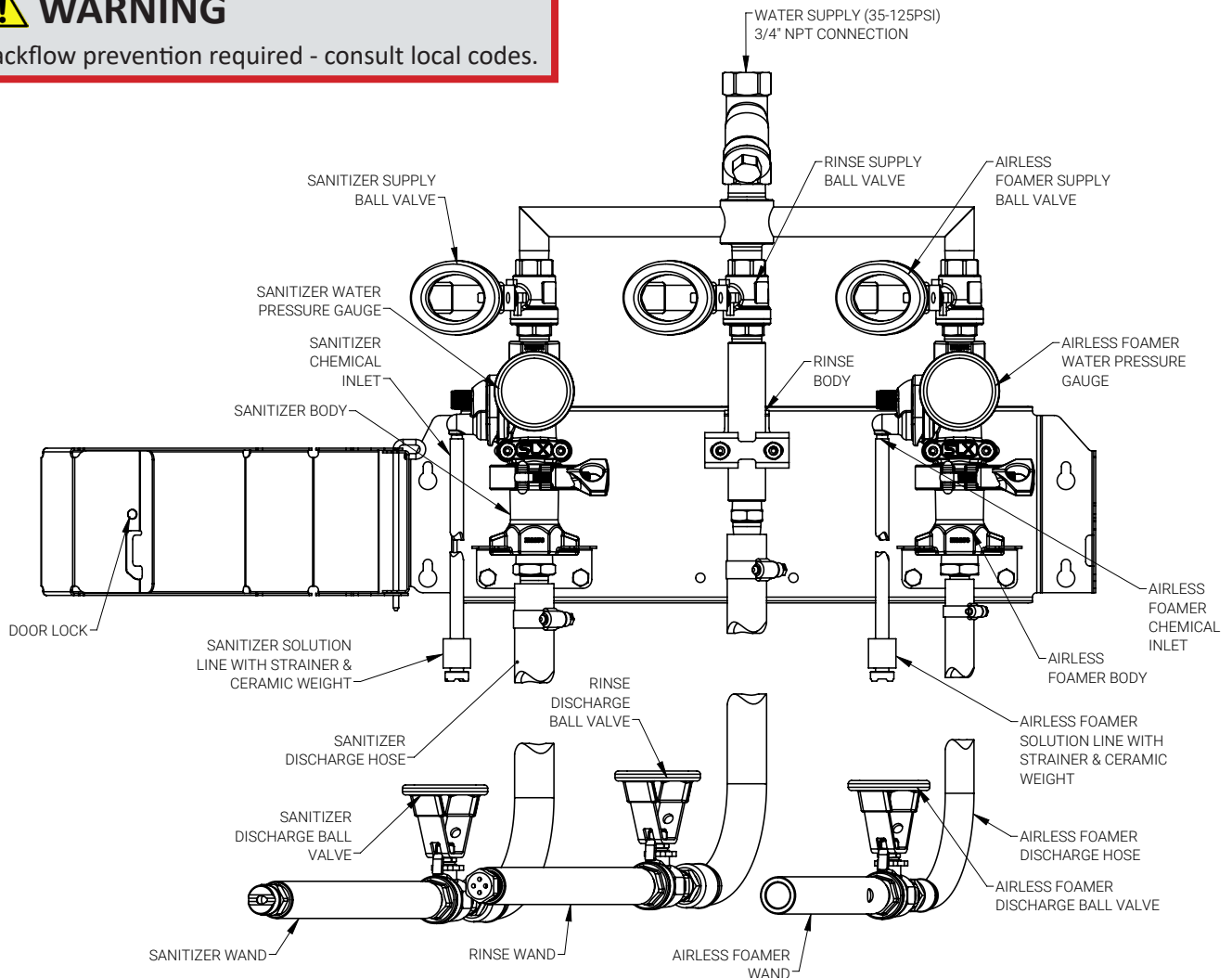
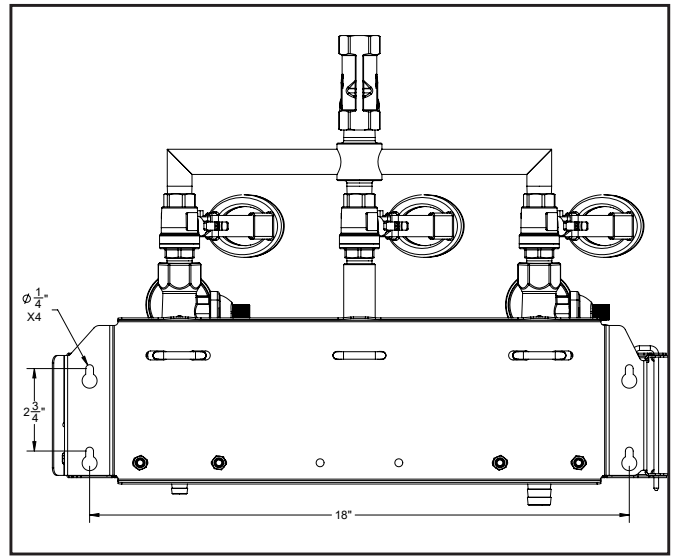

Dilution

Metering Tips

1. Place chemical container(s) below unit.
2. Using the included metering tips, identify which tip is appropriate for your dilution ratio for each system

NOTE: Review dilution recommendations for the chemistry being used. GPM's calculated at 40 PSI water pressure. For different pressure estimates use following formula:

$$\text{Dilution Ratio} = \frac{(\text{GPM} \times 128)}{\text{Oz/Gal}}$$

3. Thread metering tip into hose barb on chemical inlet to install. [Fig 5.1]
4. Connect suction line to hose barb.
5. Connect suction line in chemical container (suction line with ceramic weight and strainer included for this purpose).
6. Repeat for other unit.

NOTE: Dilution ratios for metering tips are dependent on venturi insert size. Consult the table on page 6 for the dilution ration for each foamer or sanitizer dilution range. Or use the **Metering Tip Calculator** on our mobile app.

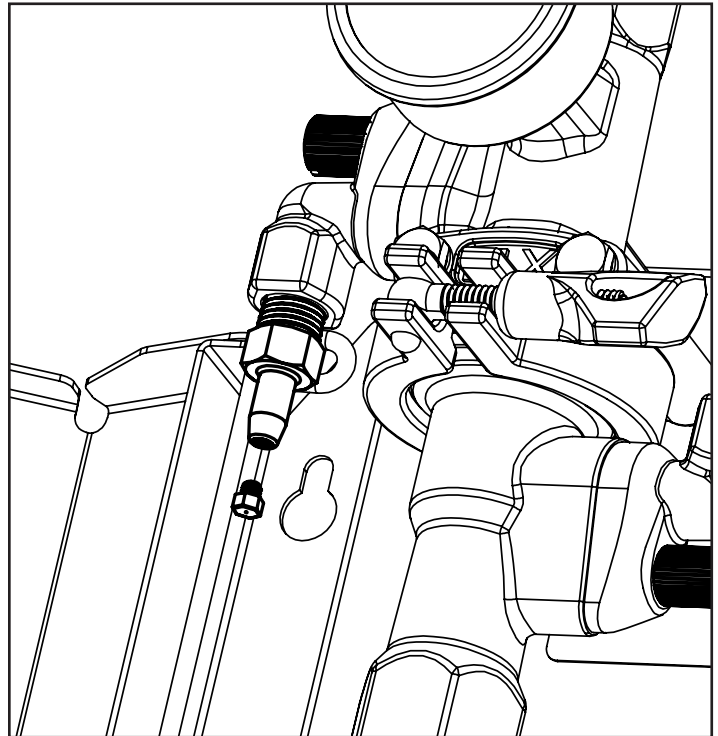
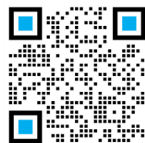

Fig. 5.1: Metering tip and hose barb

Metering Tip Calculator
Mobile App:





Dilution (cont.)

The following estimates are for guideline purposes only. Results may differ. Always test chemistry for proper dilution ratio prior to normal operation. Contact your distributor or chemical manufacturer for support or dilution recommendations.

Tip	Color	Oz/Min	V14	V54
○	Copper	0.44	407:1	1585:1
○	Pumpkin	0.54	332:1	1292:1
○	Burgundy	0.67	267:1	1041:1
○	Lime	0.85	211:1	821:1
○	Orange	1.70	105:1	410:1
○	Turquoise	2.15	83:1	324:1
⬡	Pink	2.93	61:1	238:1
⬡	Corn Yellow	3.84	47:1	182:1
⬡	Dark Green	4.88	37:1	143:1
⬡	Orange	5.77	31:1	121:1
⬡	Gray	6.01	30:1	116:1
⬡	Light Green	7.01	26:1	100:1
⬡	Med. Green	8.06	22:1	87:1
⬡	Clear Pink	9.43	19:1	74:1
⬡	Yellow Green	11.5	16:1	61:1
⬡	Maroon	11.93	15:1	58:1
⬡	Pale Pink	13.87	13:1	50:1
⬡	Light Blue	15.14	12:1	46:1
⬡	Dark Purple	17.88	10:1	39:1
⬡	Navy Blue	25.36	7:1	28:1
⬡	Clear Aqua	28.6	6:1	24:1
⬡	Black	50	4:1	14:1

UNIT FLOW RATES

PSI	insert Flow Rates	
	V14	V54
35	1.35	5.20
40	1.40	5.45
45	1.45	5.70
50	1.50	5.95
55	1.60	6.15
60	1.65	6.40
65	1.70	6.60
70	1.70	6.80
75	1.75	6.95
80	1.80	7.15
85	1.85	7.35
90	1.90	7.55
95	1.95	7.70
100	2.00	7.85
105	2.05	7.99
110	2.05	8.14
115	2.10	8.29
120	2.15	8.43

Operation

Initial Use

When operating the airless foamer for the first time some alterations may need to be made to produce the desired foam quality and ensure the unit is drawing chemistry as intended.

1. Ensure unit is properly connected and the water valve is closed [Fig. 7.1]
2. Take hold of the spray wand.
3. Open ball valve on spray wand [Fig. 7.2]
4. Fully open water valve.
 - The spray wand will slowly begin discharging water.
 - Chemical will be drawn up the suction line and introduced to the fluid path.
 - **Foamer:** Air will be drawn into the wand to create foam - this may take a few seconds to produce the desired foam quality

NOTE: Do not block air inlet on wand. If blocked, the unit will not produce foam.

5. Ensure water pressure is above 35 PSI
6. Check foam or spray quality and dilution amount per facility standards.
7. Metering tip size may need to be changed if foam or sanitizer spray quality or dilution ratio is still not adequate.

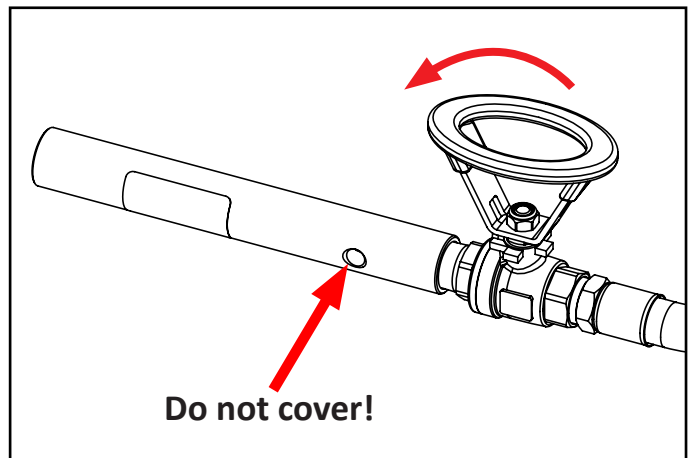
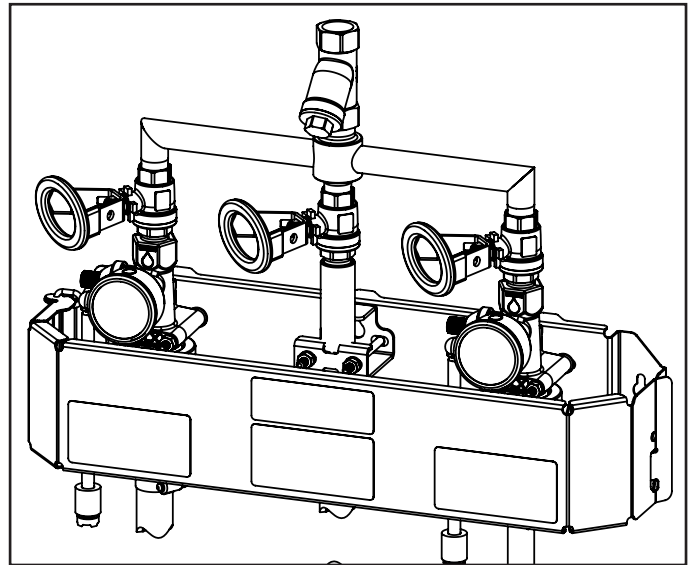
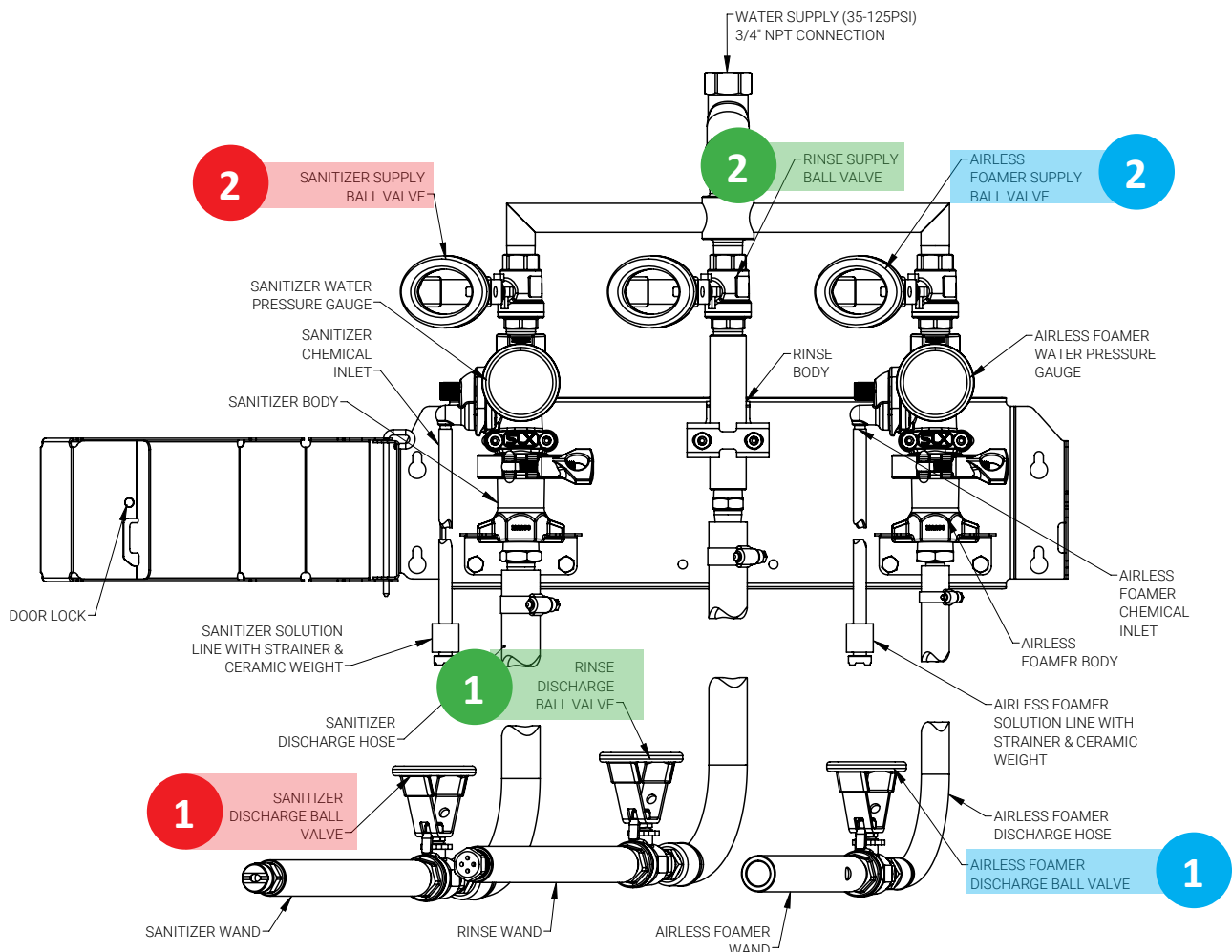

Fig. 7.2: Airless foam wand with open valve.

Operation (cont.)

Normal Use

1. Ensure system is properly connected and the water supply valves are closed [Fig. 7.1]
2. Take hold of the spray wand for the intended system
3. Open ball valve on spray wand
4. Fully open water valve.
 - The spray wand will begin discharging water.
5. Apply solution as necessary:
 - Foam: apply bottom to top, ensuring even coating. Rinse before foam dries to avoid streaking.
 - Rinse: top to bottom
 - Sanitizer: apply top to bottom
6. Turn spray wand ball valve off to temporarily stop spraying (there may be kick-back when re-opening).
7. When complete, turn off supply lines.
8. Open spray wand ball valve(s) and exhaust pressure completely.
9. Rinse hose(s) as necessary.
10. Store hoses depressurized, with the ball valve open and coiled properly coiled to prevent kinks or damage.



General Use

Removing Venturi Insert

1. Ensure supply line is off and system is depressurized.

WARNING

Depressurize system prior to servicing! Always wear appropriate personal protective equipment (PPE) when handling chemical per SDS recommendations.

2. Open the enclosure door.
3. Loosen the tri-clamp fitting to disconnect the upper and lower body.

NOTE: Supply lines and discharge hose can remain connected during this process. Ensure there is adequate hose/tubing length for maneuverability.

4. Pull the lower body down, away from the upper section.

WARNING

An o-ring is positioned between the upper and lower bodies. Ensure it is not lost during servicing.

5. With the bottom half removed the venturi insert can be accessed; pull straight down to remove.
 - Force may be required due to o-rings and/or chemical build-up.
 - A screwdriver can be used to pry the insert out if necessary [Fig. 9.2]
6. The insert can be cleaned using warm water or descaling acid compatible with PVC.

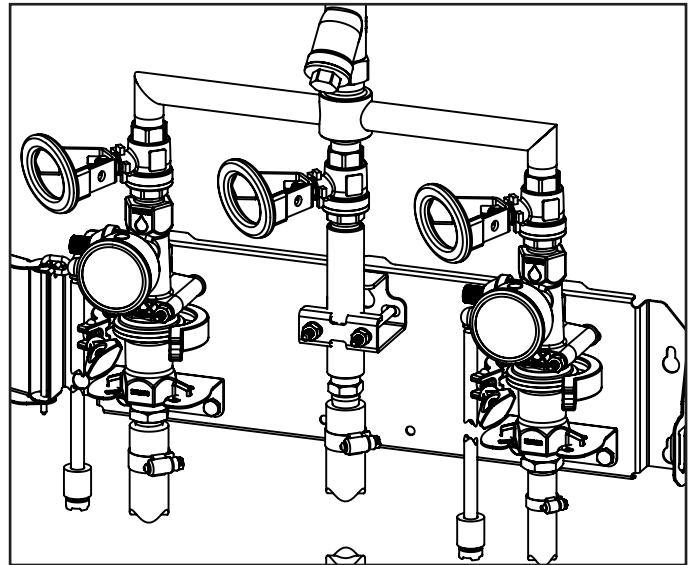

Fig. 9.1: Tri-clamp open

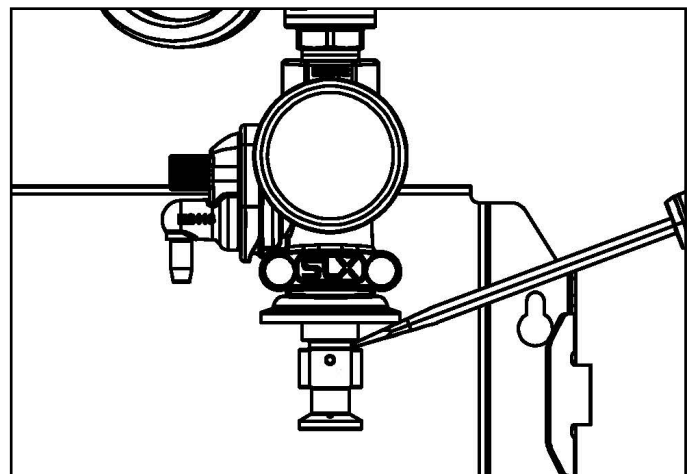

Fig. 9.2: Venturi insert removal using screwdriver

General Use (cont.)

Removing Venturi Insert (cont.)

7. Replace insert when clean or with a new version by sliding it back into the upper body, o-ring section first.
8. Reconnect the lower body to the upper section.

WARNING

Ensure o-ring is positioned between the upper and lower bodies and is seated properly. Failure to do so may result in leaks or improper performance.

9. Place the tri-clamp around the lip where the two halves meet, tighten in place until secure.
10. Ensure gauges are facing forward and all connection points are secure.
11. Close enclosure door and lock if necessary.
12. Follow initial setup procedures to test insert and foam/spray quality before resuming normal operation.

Removing Check Valve

1. Ensure supply lines are off and system is depressurized.
2. Open the enclosure door
3. Loosen the thumb screw on the elbow by hand or using a flathead screwdriver. [Fig 10.2]
4. Pull the elbow away from the main body.
5. The check valve will be seated either inside of the elbow or the body. Grab it and pull to remove. [Fig 10.3]
6. Clean or replace if damaged.
7. To reinsert, orient the check valve with the arrow pointing towards the main body and press into place.
8. Reattach the elbow and tighten the thumb screw until secure.

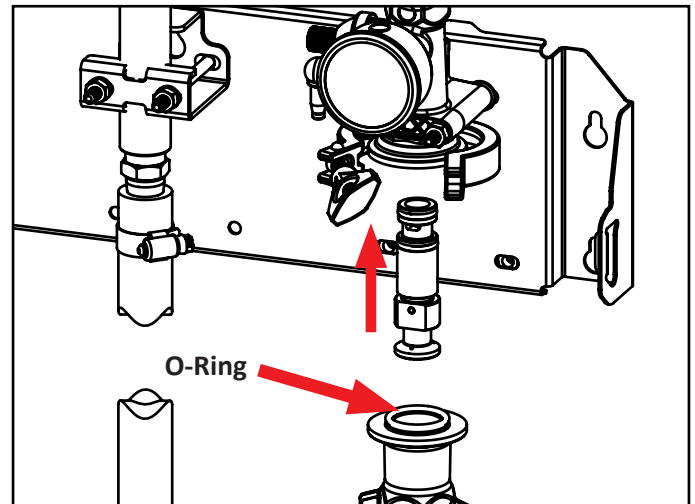

Fig. 10.1: Replacing venturi insert and foamer body

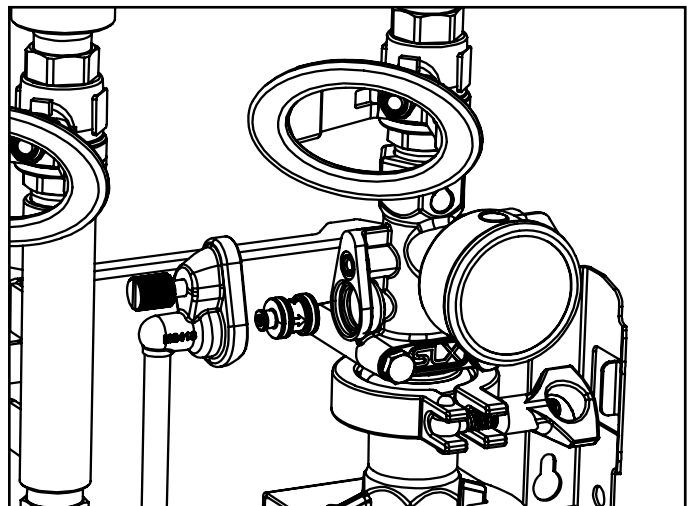

Fig. 10.2: Loosening thumb screw on elbow

Maintenance

The following maintenance procedures are recommended for normal use. Units which see a high amount of use should be inspected more frequently.

WARNING

Depressurize system prior to servicing! Always wear appropriate personal protective equipment (PPE) when handling chemical per SDS recommendations.

Daily:

- Check condition of hose (damage or leaks)
 - Replace as necessary.
- Ensure water line is not receiving backflow of chemistry.
 - Ensure check valves are operating properly, replace as necessary.
- Verify ball valves are operating properly.
 - Replace as necessary.

Weekly:

- Ensure metering tip is free of clogs
 - Remove from chemical inlet and clean with water.
- Ensure tri-clamp is secure and bodies are sealed
 - Verify o-ring is seated properly and is not damaged. Replace as necessary.
 - Check that tri-clamp is seated properly and tighten till secure.

Monthly

- Verify check valves are operating properly
 - Remove and ensure spring is functioning properly. Replace as necessary.
- Check venturi insert for clogs and debris.
 - Remove and inspect - if clogged or scale has built up clean with water or de-scaling acid compatible with PVC.
- Check o-rings on inserts and check valves.
 - Remove and replace as necessary.
 - O-rings can be purchased individually or pre-installed as complete check valve or insert assemblies.

Annually

- Replace discharge hose (and wand if necessary)
- Replace insert, check valves, regulators, and gauges



More Information

Please contact Clean Logix at:

(616)-438-9200 or **sales@clean-logix.com**



Troubleshooting

Venturi will not draw chemical

	Cause	Solution
	Water pressure or water volume too low/inlet piping too small causing poor chemical pick up	Increase water pressure or water volume
	Inlet or discharge ball valve is not completely open	Completely open the ball valves.
	Not enough chemistry is being diluted	Install larger metering tip to use more chemistry
	Improper chemical	Ensure product is recommended for foaming and the intended application.
	Chemical supply is empty or suction line is not fully submerged	Immerse tube or replenish chemical in container.
	Discharge hose too long or wrong size or kinked	Straighten the hose or replace hose with correct size and length.
	Wand size is incorrect	Replace wand with correct size.
Extended Use	Insert is clogged	Open foamer body and check for debris or obstructions. Clean as necessary with water or air.
	Chemical strainer or metering tip partially blocked	Clean or replace chemical strainer and/or metering tip.
	Chemical tube stretched out or pin hole/cut in chemical tube sucking air.	Cut off end of tube or replace tube.
	Vacuum leak in chemical pick-up connections	Tighten the connection.
	Chemical check valve stuck or failed	Clean or replace.
	Airless Foam Wand screen clogged	Remove fittings and soak wand in descaling acid.
	Hard water scale or chemical build-up may have formed in the foamer body causing poor or no chemical pick-up	Open foamer body and check for build-up. Remove and clean with water or descaling acid (insert is PVC). Replace as necessary.

Foamer does not clean properly

Cause	Solution
Not enough chemistry is being diluted	Install larger metering tip to use more chemistry
Improper chemical	Ensure product is recommended for foaming and the application.
Hose may be damaged or kinked.	Straighten the hose, replace if damaged.
Incorrect discharge hose or wand.	Verify size and replace if necessary with correct size and length (see system specifications based on insert size)



Troubleshooting

Foam is too wet

	Cause	Solution
Start-up	Water pressure or water volume too low/inlet piping too small causing poor chemical pick up	Increase water pressure or water volume
	Inlet or discharge ball valve is not completely open	Completely open the ball valves.
	Chemical ball valve not open (2-way only)	Open chemical ball valve
	Not enough chemistry is being diluted	Install larger metering tip to use more chemistry
	Improper chemical	Ensure product is recommended for foaming and the application.
	Chemical supply is empty or suction line is not fully submerged	Immerse tube or replenish.
	Wand size is incorrect	Replace wand with correct size.
Extended Use	Chemical strainer or metering tip partially blocked	Clean or replace chemical strainer and/or metering tip.
	Chemical tube stretched out or pin hole/cut in chemical tube sucking air.	Cut off end of tube or replace tube.
	Vacuum leak in chemical pick-up connections	Tighten the connection.
	Chemical check valve stuck or failed	Clean or replace.
	Hard water scale or chemical build-up may have formed in the foamer body causing poor or no chemical pick-up	Open foamer body and check for build-up. Remove and clean with water or descaling acid (insert is PVC). Replace as necessary.

Venturi is using too much chemistry

Cause	Solution
No metering tip installed or metering tip too large	Install smaller metering tip.

Water is backing up into chemical container

Cause	Solution
Chemical check valve stuck or failed	Clean or replace.

For Technical Support:



Parts Call-Out

Parts will vary depending on venturi insert size and body material. Review the parts list and following diagrams for the different system types to identify replacement parts for your specific system.

Purchase Replacement Parts:

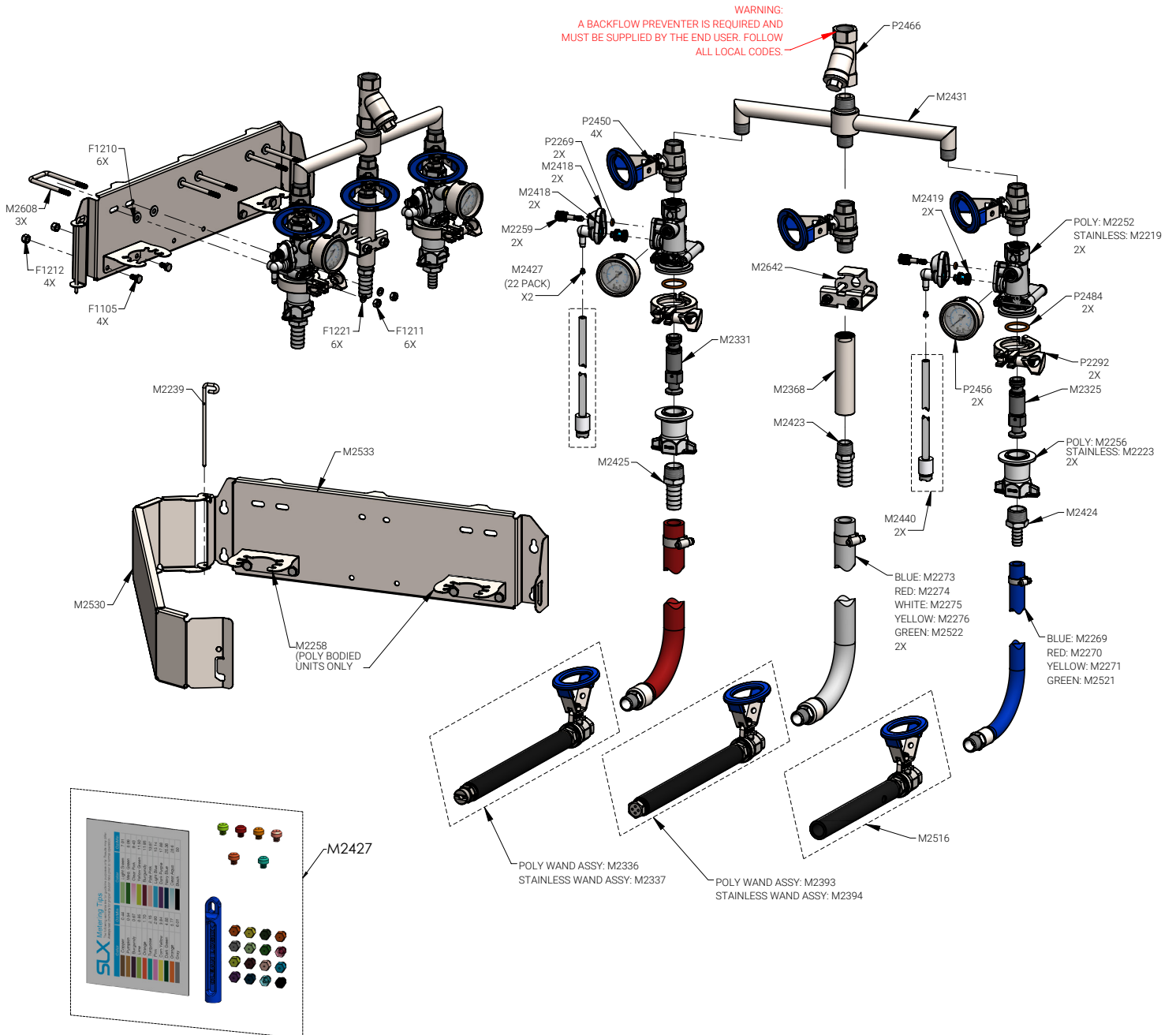

USER MANUAL: SLX-MS3-VS-RN-VA

READ ALL INSTRUCTIONS BEFORE OPERATING EQUIPMENT



Parts Call-Out

Part Number	Description
F1105	BOLT, HHC, 1/4-20 X 1/2", SS
F1210	WASHER, FLAT, 1/4" X 5/8", 316SS
F1211	NUT, 1/4-20, 316SS
F1212	NUT, NYLOCK, 1/4-20, 316SS
F1221	WASHER, SPLIT LOCK, 1/4" X .487", 316SS
M2219	SLX UPPER BODY, TYPE-1V, SS
M2223	SLX LOWER BODY, TYPE-S, SS
M2224	SLX CHECK ELBOW, 1/4 FNPT, SS
M2239	SLX HINGE PIN V2.1
M2252	SLX UPPER BODY, TYPE-1V, PP
M2256	SLX LOWER BODY, TYPE-S, PP
M2258	SLX LOWER SUPPORT BRACKET
M2259	SLX THUMB SCREW
M2269	HOSE ASSEMBLY, 1/2" X 50', PVC, BLUE, 1/2" MNPT ONE END
M2270	HOSE ASSEMBLY, 1/2" X 50', PVC, RED, 1/2" MNPT ONE END
M2271	HOSE ASSEMBLY, 1/2" X 50', PVC, YELLOW, 1/2" MNPT ONE END
M2273	HOSE ASSEMBLY, 3/4" X 50', PVC, BLUE, 1/2" MNPT ONE END
M2274	HOSE ASSEMBLY, 3/4" X 50', PVC, RED, 1/2" MNPT ONE END
M2275	HOSE ASSEMBLY, 3/4" X 50', PVC, WHITE, 1/2" MNPT ONE END
M2276	HOSE ASSEMBLY, 3/4" X 50', PVC, YELLOW, 1/2" MNPT ONE END
M2325	SLX INSERT ASSEMBLY, V14, W/ AFLAS SEALS
M2331	SLX INSERT ASSEMBLY, V54, W/ AFLAS SEALS
M2368	SLX RINSE COUPLER
M2393	SLX WAND ASSEMBLY, 1/2" BALL VALVE, 4-HOLE RINSE NOZZLE, 10" PP WAND
M2394	SLX WAND ASSEMBLY, 1/2" BALL VALVE, 4-HOLE RINSE NOZZLE, 10" SS WAND
M2418	SLX CHECK ELBOW, METERING BARB, PP

Part Number	Description
M2419	SLX CHECK VALVE, BALL TYPE, AFLAS SEALS, HASTELLOY SPRING, 0.5LB
M2423	PIPE ADAPTER, HOSE BARB, 1/2" NPT X 3/4" BARB, 316SS, 150 PSI
M2424	PIPE ADAPTER, HOSE BARB, 3/4" NPT X 1/2" BARB, 316SS, 150 PSI
M2425	PIPE ADAPTER, HOSE BARB, 3/4" NPT X 3/4" BARB, 316SS, 150 PSI
M2427	SLX METERING TIP FULL KIT - 22 TIPS AND DRIVER
M2431	SLX MANIFOLD TRIPLE - WELDED
M2435	SLX SECURITY SCREW - SOCKET
M2440	SLX SUCTION LINE ASSEMBLY 1/4" X 6' WITH STRAINER AND WEIGHT
M2516	SLX AIRLESS FOAM WAND ASSEMBLY, 1/2" BALL VALVE, .116 POLY
M2521	HOSE ASSEMBLY, 1/2" X 50', PVC, GREEN, 1/2" MNPT ONE END
M2522	HOSE ASSEMBLY, 3/4" X 50', PVC, GREEN, 1/2" MNPT ONE END
M2530	SLX CLAMSHELL BACKPLATE V4.2 SIZE 3
M2533	SLX CLAMSHELL DOOR V4.2 SIZE 3
M2608	SLX U-BOLT, 3.375" x 1.75" x 1/4"-20 - 0.75", 304SS
M2642	BRACKET, SLX RINSE STATION, C-BRACKET
P2269	O-RING, -106, .109" X .380" OD, Viton, Brown
P2292	SANITARY FLANGE CLAMP, 1.0-1.5, 304
P2450	VALVE, BALL, 1/2" FNPT X 1/2" MNPT, 316SS, PTFE, 1000 PSI
P2456	GAUGE, PRESSURE, 2", 0-150psi, 1/4" NPT, SS
P2466	STRAINER, Y, 3/4" NPT, 316SS, 140 MESH (100 MICRON), 800 PSI
P2484	O-RING, SLX BODY, VITON, BROWN



More Information

Please contact Clean Logix at:

(616)-438-9200 or sales@clean-logix.com