

# SLX-MS



## PUMP FED FOAM & FOAM

The SLX Double Foam multi-station provides a dual cleaning system for industrial processing equipment using multiple ready to use (RTU) cleaning solutions (35-125 PSI) from one location with two discharge hoses.

This low to medium volume centralized cleaning system uses two pumps to supply ready to use, pre-diluted, cleaning solutions for two separate foam proportioner. Both foamers are securely mounted onto a stainless-steel wall bracket for easy installation.



## FEATURES:

- Split body design for easy servicing and maintenance (patent pending)
- Tool free disassembly (even the check valves and plumbing components)
- Large fan nozzle for efficient foam coverage
- Adjustable consistency (dry vs. wet foam)
- Modular components to alter flow rates
- Heavy duty, durable construction
- Lockable stainless-steel cover
- Includes pressure gauges for air
- Large stainless steel ball valves at inlet and outlet with 1/2" NPT connections

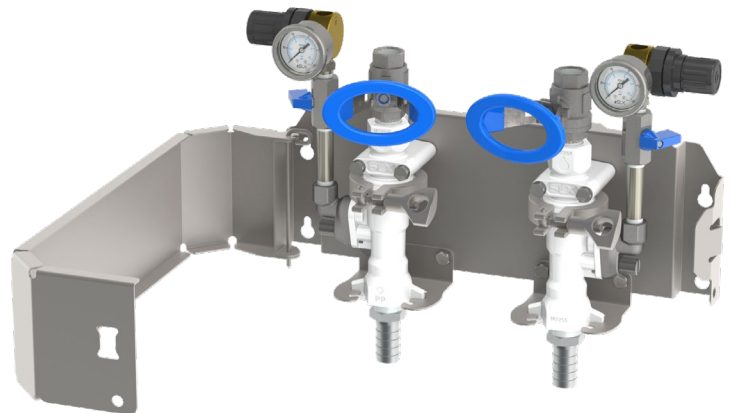

Dimensions	15" x 11-5/8" x 6"
Max Temperature	160°F
Pump Pressure	35-125 PSI
Air Pressure*	40 PSI (up to 5 CFM)

\*Air pressure recommended 40PSI, adjust for foam quality.

## INCLUDES:

- Polypropylene Pump Fed Foamer with 3/4" x 50' hose (2x)
- 10" polypropylene spray wands with fan nozzles (2x)
  - Stainless and/or jet nozzle upgrade available
- Stainless steel mounting bracket and cover

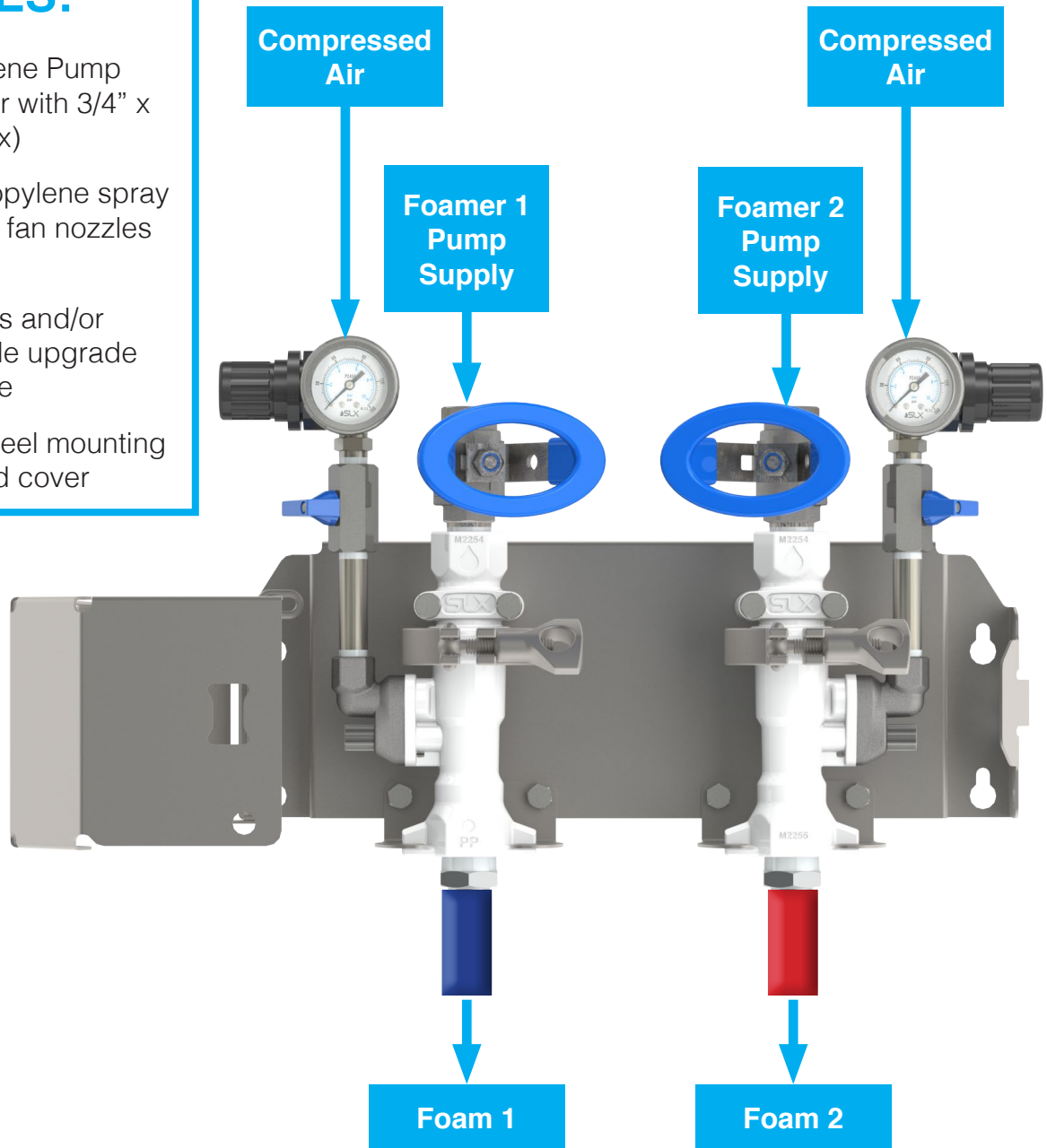

## SPECIFICATIONS

Part #	Foam Coverage Time (sq/ft per min)	Foam Flow Rate (GPM)	Foam Water Flow Rate (GPM)
SLX-MS2-PF21P-PF21P	250	7 - 14	1.4