

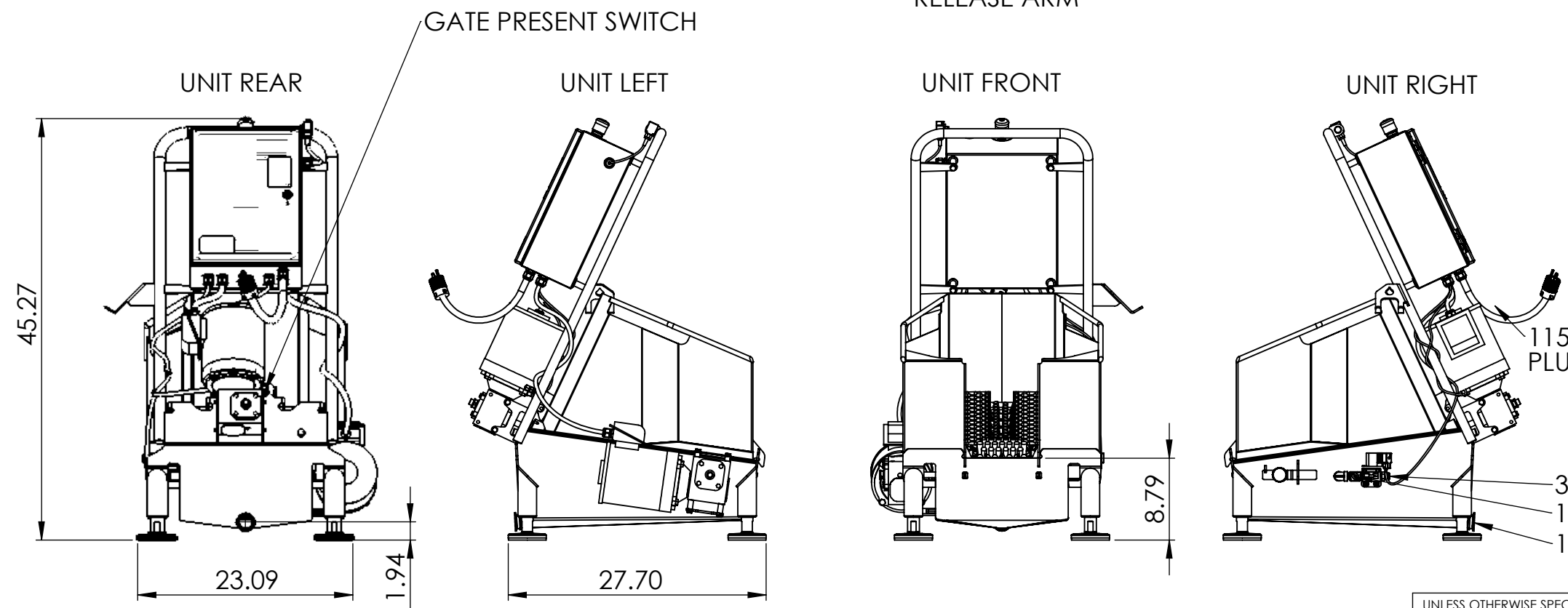

REVISIONS		
REV.	DESCRIPTION	DATE
103	INITIAL RELEASE	11/8/2021

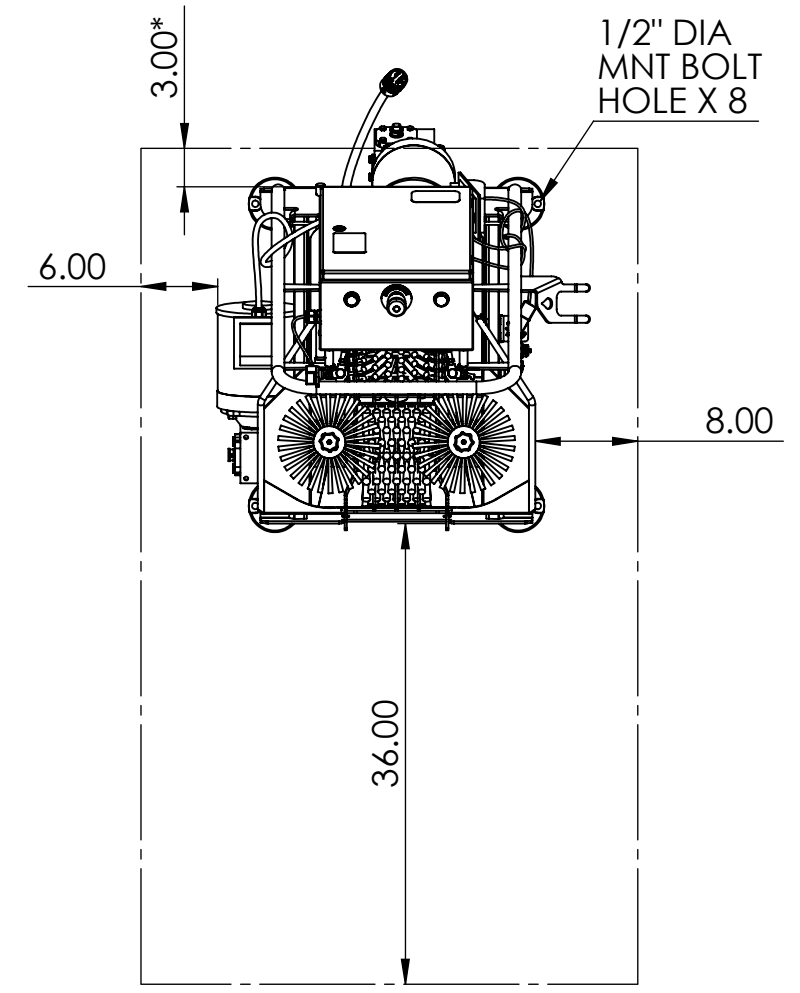
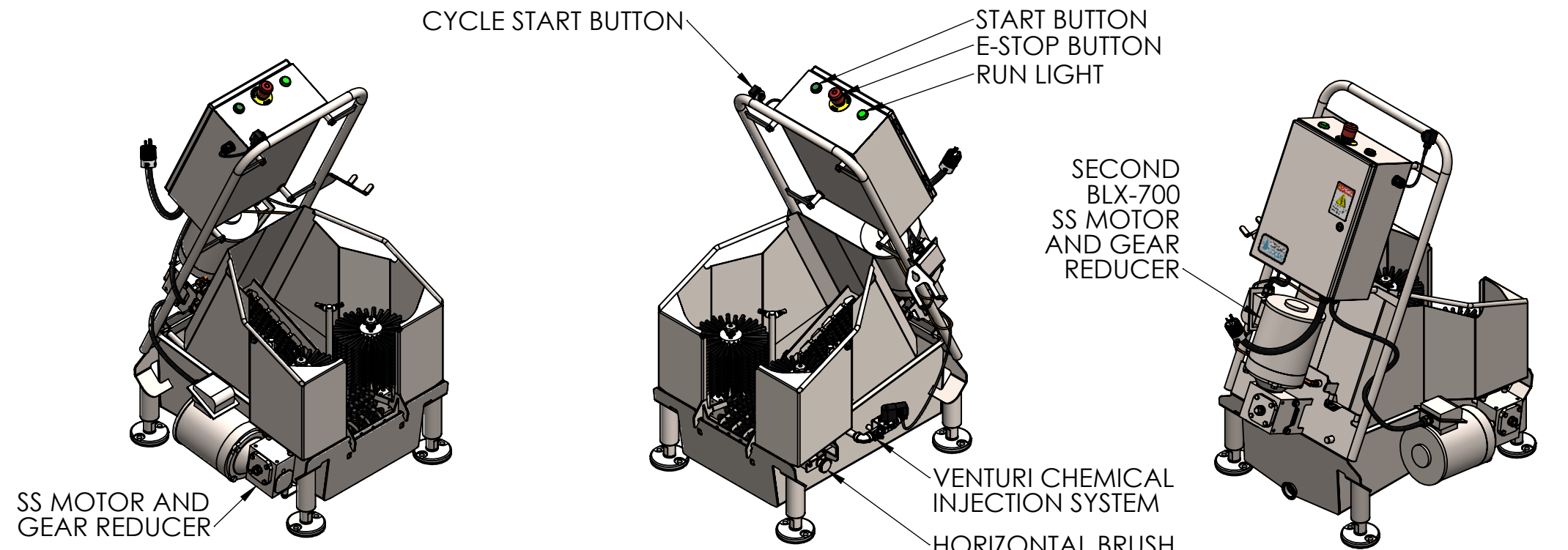

MINIMUM MOUNTING DISTANCES

*NOTE: FOR FIXED INSTALLATIONS, AREA IN FRONT OF ELECTRICAL PANEL MUST BE CLEAR AT LEAST 36"

UNLESS OTHERWISE SPECIFIED: DIMENSIONS ARE IN INCHES TOLERANCES: FRACTIONAL ± 1/16" ANGULAR: MACH ± .5° BEND ± 2° TWO PLACE DECIMAL ± .015" THREE PLACE DECIMAL ± .005"		PROPRIETARY AND CONFIDENTIAL! THE INFORMATION CONTAINED IN THIS DRAWING IS THE SOLE PROPERTY OF CLEAN-LOGIX. ANY REPRODUCTION IN PART OR AS A WHOLE WITHOUT THE WRITTEN PERMISSION OF CLEAN-LOGIX IS PROHIBITED.		
MATERIAL	FINISH	WEIGHT (LB.)	241.60	
				TITLE: BLX-700-GEN2 REV103
				ITEM NUMBER: BLX-700-GEN2 SAMPLE BUILD
				SCALE: 1:20
				SHEET 7 OF 21